

# NAVI-TRAC FRAME LIFT

## ASSEMBLY INSTRUCTIONS

1100 Burch Drive.  
Evansville, Indiana 47724



Phone: 812-867-2421  
Fax: 812-867-0547  
E-mail: www.anchorinc.com

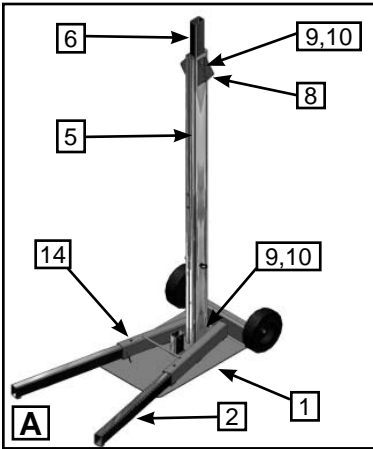

### See Image "A"

1. Attach the lower end (2-hole pattern) of the Bottom Post (#5) to the rear most splice stub of the Base Weldment (#1) (use Hdw #9 & 10). The single, centered channel of the post should face forward.
2. Insert the Leg Inserts (#2) and pin with (#14).
3. The Turf Wheels (#21) have been pre-installed.
4. One at a time, remove the bolts (#9 & 10) holding the splice at the top of the Bottom Post (#5) to install the Hinges for Brace (#8) on each side of the bottom post. Secure the hinges by replacing the same hardware (9 & 10).

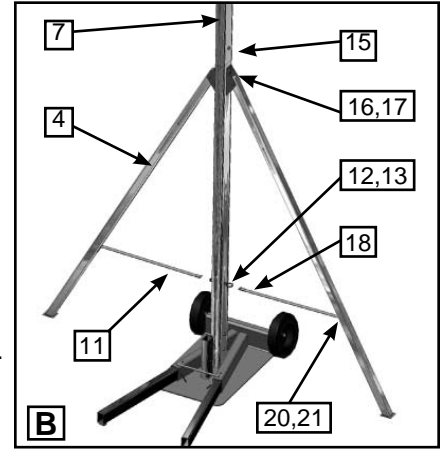

### See Image "B"

5. Install the Brace Weldments (#4) to the Brace Hinges (#8) on both sides of the bottom post (use hdw #16 & 17) at the brace hinge (#8)
6. Lean the Frame Lift over, as needed, to slide the Top Post (#7) onto the Splice of the bottom post and secure (use hdw #15).
7. To limit the spread of the Brace Weldments, install Eyes (#12 & 13) into the bottom post and attach the 36" web (#11) between the brace (use hdw #20 & 21) and the bottom post (use snap #18).

### See Images "C, D, & E"

8. While the Frame Lift is leaned over, attach the pre-assembled lifting web and winch assembly starting with the Winch Assembly (#24) to the Bottom Post (use hdw #25 & 26). See images C and D.

**Winch Assembly**

**Warning:**  
Always position winch assembly as shown in image "D". Do not attach upside down - winch brake system may fail.

**Winch Assembly properly mounted**

For warnings, maintenance and replacement parts, refer to the Dutton-Lainson booklet that is shipped with this winch (the B1500)

9. Next, feed the web assembly to the top and insert the Web Top Weldment (#3) into the top of the Top Post (#7) and secure with (hdw #9,10). The Eave Hook (#27) should hang at the front of the Lift with the cup forward and can be secured to the front splice stub of the base plate when not in use. See Image "F" for storage of the Frame Lift when not in use.

10. Follow the instructions in the Navi-Trac Assembly Manual for proper positioning and use of the Navi-Trac Frame Lift for assembling and standing the Navi-Trac frame.

PART LIST		
ITEM #	QTY	DESCRIPTION
1	1	BASE WELDMENT
2	2	LEG INSERT
3	1	WEB GUIDE TOP WELDMENT
4	2	BRACE WELDMENT
5	1	BOTTOM POST
6	1	SPLICE TOP POST
7	1	TOP POST
8	2	HINGE FOR BRACE
9	3	1/2" x 3" HEX HD CAP SCREW
10	3	1/2" ST'D NC NYLOCK NUT
11	2	1" POLYPRO WEB
12	1	1/2" x 3 1/4" EYE BOLT
13	1	1/2" EYE NUT
14	2	1/2" x 3 1/4" FAS PIN
15	3	1/2" x 2 3/4" TENSION LOCK PIN
16	2	1/2"-13 x 3 1/4" HEX HD CAP SCREW
17	2	1/2"-13 NYLOCK JAM NUT
18	2	SNAP
19	4	#10 FENDER WASHER
20	4	1" x #10 TEC SCREW
21	2	3 1/2" x 10 1/2" DIA. TURF WHEEL
22	2	1/2"-13 x 5" HEX HD CAP SCREW
23	2	1/2"-13 HEX NUT
24	1	WINCH ASSEMBLY
25	2	3/8"-16 x 5 1/2" HEX HD CAP SCREW
26	2	3/8"-16 UNC HEX NUT
27	1	EAVE HOOK
28	25'-6"	1 1/2" POLYESTER WEB

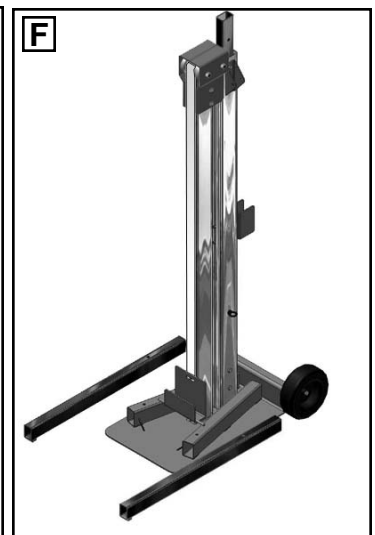
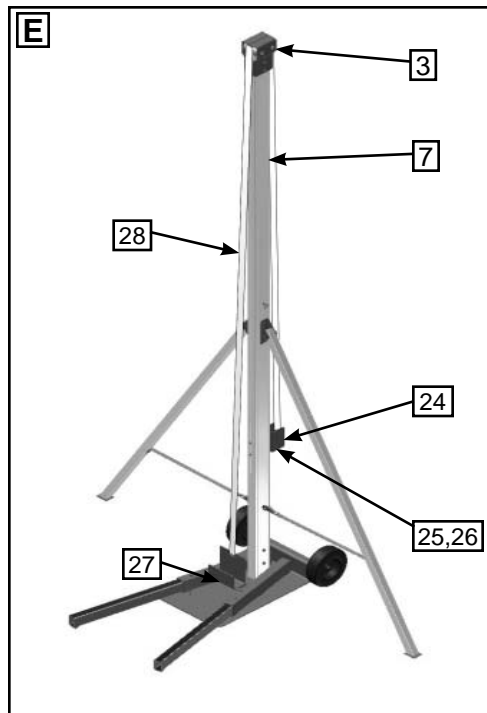

The Top Post can be stored on the front splice stub of the base plate when not in use.

Thank you for purchasing an Anchor product. In return, we pledge quality, service and craftsmanship and are available for any questions you may have or assistance you may need.

Phone Number  
**(812) 867-2421**

Fax Number  
**(812) 867-0547**

Anchor products are of superior design and operate best within the parameters of these instructions. It is imperative that the instructions be carefully read and completely followed. Please read assembly instructions before the use of this product. Because this product may be used on a variety of Anchor tent products, you should also read the installation instructions for the specific tent with which this tool is to be used. Tent installation instructions are available at: [www.anchorinc.com](http://www.anchorinc.com).

### CAUTION:

1. Use for installation of framed tent products only. Read relevant tent installation instructions.
2. Never exceed the maximum operating load stated within these instructions. Excess load may cause premature failure and could result in serious personal injury.
3. Do not oil or grease the brake mechanism of this frame lift.
4. Never apply load to winch with web fully extended. Keep at least three full turns of web on the reel at all times.
5. During use, be sure web is neither twisted nor wrapped around the pole.
6. Follow instructions carefully, paying particular attention to all safety or cautionary comments.

Proper safety equipment should be used at all times to insure a safe operation. We suggest a careful evaluation be made to determine safety equipment needed, such as hard hats, steel-toe shoes, safety glasses and other as required.

Disclaimer - Anchor Industries disclaims and excludes all express or implied warranties of merchantability and fitness for a particular purpose. The product is sold "as is" and no warranty shall apply. The user shall determine the suitability of the product for the intended use and assumes all risk and liability. Anchor Industries shall not be liable in tort or in contract for any loss or damage, direct, incidental or consequential arising out of the use of or the inability to use the product.