

Assembly Instructions

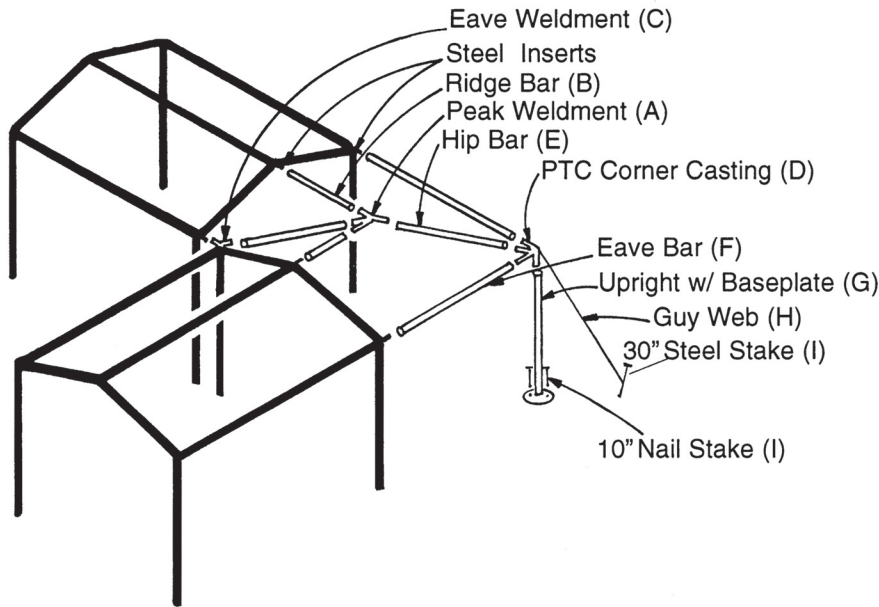

UNIT ASSEMBLY PACKING LIST

Description		Qty
(A) Peak Weldment w/4 Valco Buttons		1
(B) Ridge Bar		2
(C) Eave Weldment w/1 Valco Buttons		1
(D) PTC Complete Assembly		1
(E) Hip Bar		2
(F) Eave Bar		2
(G) Upright w/ Base Plate		1
(H) Guy web		1
(I) 30" Steel Stake		1
(J) 10" Nail Stake		2

L-Shaped Fiesta® Marquee Frame

1. Insert (1) Steel insert with Valco button into both the ridge casting and eave casting on completed Marquee Frame #1.
2. Insert eave weldment (C) into eave casting for inside corner on completed Marquee frame #1 then attach onto inserts from Step 1, eave bar (F), ridge bar (B) and hip bar (E) onto eave weldment (C).
3. Insert peak weldment (A) onto opposite end of ridge bar (B) and insert (2) hip bars (E) onto peak weldment (A).
4. Insert PTC casting (D) into upright (G) and insert hip bar (E) into PTC castings and pin (D) then clamp (2) eave bars (F) in between jaws of PTC castings (D).
5. Insert (1) steel insert w/ valco button into both the ridge castings and eave casting on completed Marquee frame #2.
6. Insert other ridge bar (B) into peak weldment (A) then attach opposite ends of eave bar (F), ridge bar (B) and remaining end of eave weldment (C) to completed Marquee frame #2.
7. Spread top over frame mating spring strips together and adjust tension on straps.
8. Snap on guy webs (H) to eye bolt.
9. Use (2) nail stakes (J) to keep upright vertical (drive nail stakes through holes in base plates). Drive large stake (I) near upright base plate (when applicable) and tension guy web.



SALES OFFICES:
1100 BURCH DR.
P.O. BOX 3477
EVANSVILLE, IN 47733 USA

PHONE 812-867-2421
FAX 812-867-0547
1-800-544-4445

PRODUCTION FACILITIES:
BRADENTON, FL
EVANSVILLE, IN



Thank you for purchasing an Anchor product. In return, we pledge Quality, Service and Craftsmanship and are available for any questions you may have or assistance you may need.

PHONE NUMBER

812-867-2421

FAX NUMBER

812-867-0547

Anchor products are of superior design and operate best within the parameters of these instructions. It is **IMPERATIVE** that the instructions be carefully read and **COMPLETELY FOLLOWED**. Please read installation instructions before the installation or removal of this product. Installation instructions are available at www.anchorinc.com.

For additional assistance consult: "The IFAI Procedural Handbook For The Safe Installation And Maintenance Of Tentage" and the IFAI "Pullout Capacity Of Tent Stakes", both available from the IFAI Tent Rental Division.

CAUTION:

1. For each installation, the installer is solely responsible for evaluating the site and the proper securing method determined. Some soils require different staking or securing than that provided with the tent. Due to this variety of soil conditions, these are the manufacturer's suggested sequence of installation procedures. Anchor's responsibility is limited to the construction of the tent. We are not responsible for methods that installers may choose to secure the tent to the ground.
2. Inasmuch as the weather is unpredictable, good judgment and common sense must be incorporated within installation guidelines. It is the responsibility of the tent installer/maintainer to determine the severity of the weather, proper time and method of installation and/or erection and disassembly.

This product has been manufactured for use as a temporary structure. For the safety of all occupants, evacuation is recommended if threatening weather occurs, or if there is any doubt concerning the safe use of this product.

3. Proper safety equipment should be used at all times to insure a safe installation and take down. We suggest a careful evaluation be made to determine safety equipment needed, such as hard hats, steel-toe shoes, safety glasses and other as required.
4. Anchor stands behind its products in accordance with its standard Terms and Conditions of sale. A copy of our Terms and Conditions of Sale can be obtained by contacting Anchor at the telephone number and/or address on this document.