

Assembly Instructions

Window/Hard Wall Installation

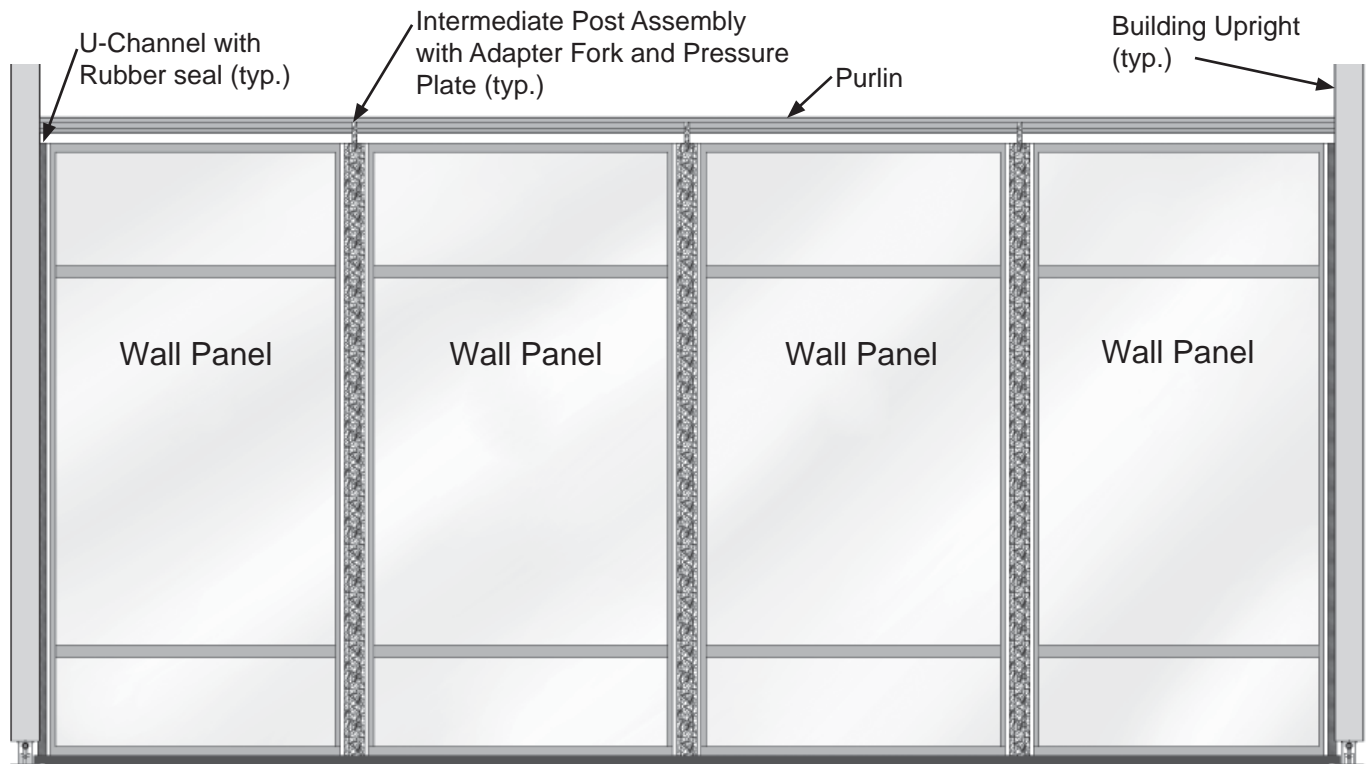

ELEVATION
Outside View

Wall Base



Please read all assembly / installation instructions before the installation or removal of this product.

SALES OFFICES:
1100 BURCH DRIVE
PO BOX 3477
EVANSVILLE, IN 47733 USA

PHONE: 812-867-2421
FAX: 812-867-0547
1-800-544-4445
EMAIL: tents@anchorinc.com
www.anchorinc.com

PRODUCTION FACILITIES:
EVANSVILLE, IN

INSTALL KIT ASSEMBLY AND WALL PANEL INSTALLATION

1. Install the wall base equally spaced between the uprights. Position the wall base so that the back lip is toward the interior of the tent. See Figure 1.
2. Install the U-Channels in the uprights by engaging the “L” leg into the outside kedar groove of the upright and rotating the U-Channel toward the interior of the tent until the flat portion of the “U” contacts the upright. At this point, if the wall base is positioned correctly, the U-Channel will drop down into the notch at each end of the wall base.
3. Remove the bolts, washers and pressure plates from all of the intermediate posts. Save for re-use after the wall panels are installed.
4. Remove the bolts and washers from the adapter forks and slide the vertical portion of the fork inside the top of the post, but outward of the spacer tube inside the post. See Figure 2.

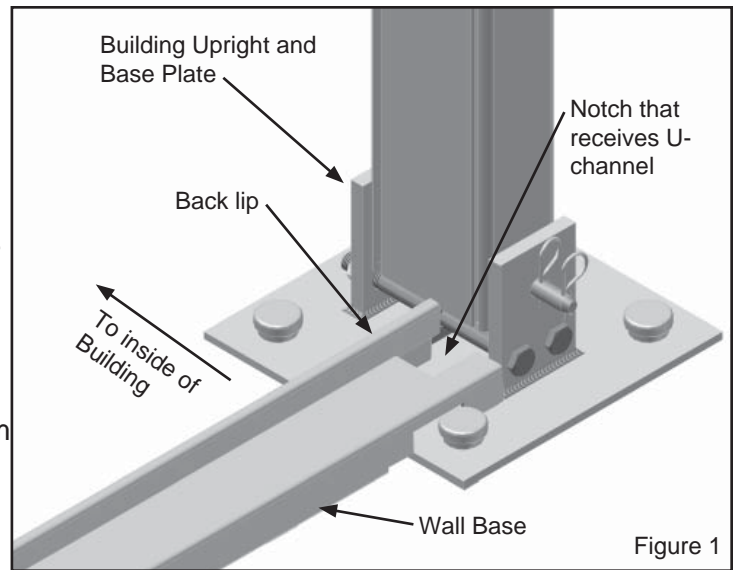

Figure 1

Note: **DO NOT** insert the fork inside the spacer tube. Re-install the washers and bolts in the vertical portion of the adapter fork and loosely tighten so the fork is allowed to slide in and out.

5. At about 48” away from the side U-Channel, position the first intermediate post on the wall base so that the “Z” clip on the bottom of the post engages the back lip of the wall base. See Figure 3. Rotate the post to a plumb position while engaging the “U” portion of the fork with the purlin above. Slide the adapter fork up until the bottom of the “U” portion of the fork contacts the bottom of the purlin. Snuggly tighten the bolts that fasten the fork to the post. Note: These bolts and the setscrew in the fork must be securely tightened once the wall panels are in position.

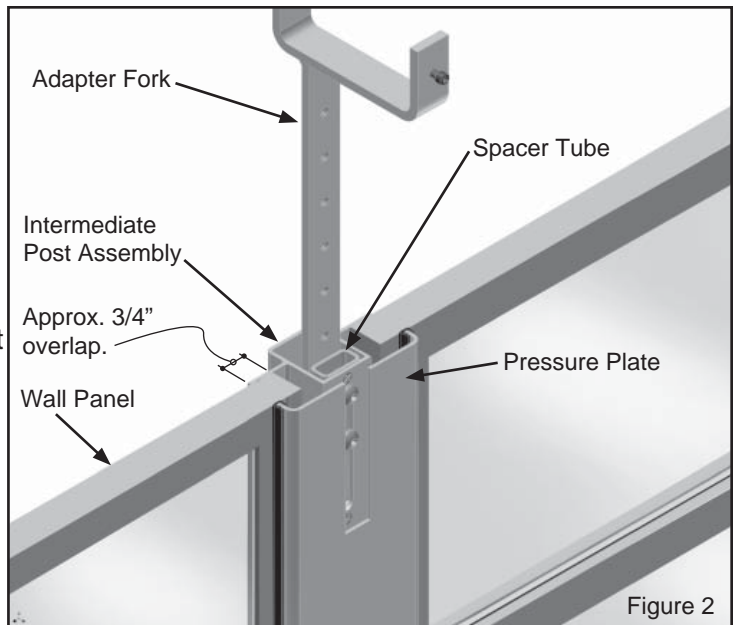

Figure 2

6. The install kit assembly is now ready to receive the first wall panel.
7. The orientation of the wall panel is correct when the smaller pane of glass is on the bottom and the glazing stops are toward the interior of the tent.
8. First engage one side of the wall panel into the U-Channel, then pivot the opposite side toward the intermediate post until the inside face of the wall panel contacts the lip on the wall base. (Note: If the intermediate post is in the way, slide it out of the way to allow the panel to pivot back against the lip on the wall base.) Once the wall panel is in place, slide the intermediate post back toward the wall panel until the leg of the post overlaps the outside face of the wall panel by approximately $\frac{3}{4}$ ". Install the pressure plate to the intermediate post, but do not tighten the bolts so that the adjoining wall panel can be placed on the opposite side of the intermediate post. See Figure 2.

9. Install the second wall panel by placing it on the wall base and sliding the side between the intermediate post and the loosely installed pressure plate. Install the second intermediate post as noted above in step 5 and slide the intermediate post toward the wall panel until the leg of the post overlaps the wall panel approximately $\frac{3}{4}$ ". Loosely install the pressure plate as described in step 8.
10. Before installing the third panel, install the fourth panel adjacent to the upright by installing the U-Channel in the upright and installing the third (& last) intermediate post as described in steps 2 – 8. Leave the pressure plate off the third intermediate post until the third (& last) wall panel is in place.
11. Now the third wall panel can be placed between the second and third intermediate posts. The intermediate posts may need to be spread apart to allow the placement of the third wall panel. Once the third panel is in place, secure the pressure plate on the third intermediate post.
12. Before tightening the bolts securing the pressure plates to the intermediate posts, adjust the wall panels and intermediate posts so they are equally spaced and the intermediate posts are plumb.
13. Tighten all the pressure plate bolts, adapter fork bolts and the setscrews securing the adapter forks to the purlin.
14. Finally, install the rubber seals between the U-Channels and the interior face of the wall panels. Note: It's best to begin engaging the seal at either the top or the bottom and work to the opposite end. See Figure 4.

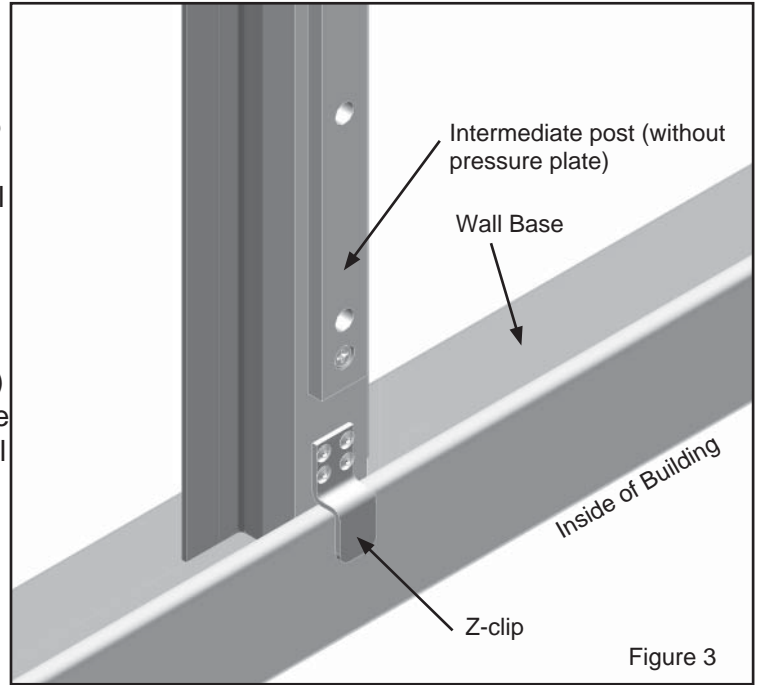

Figure 3

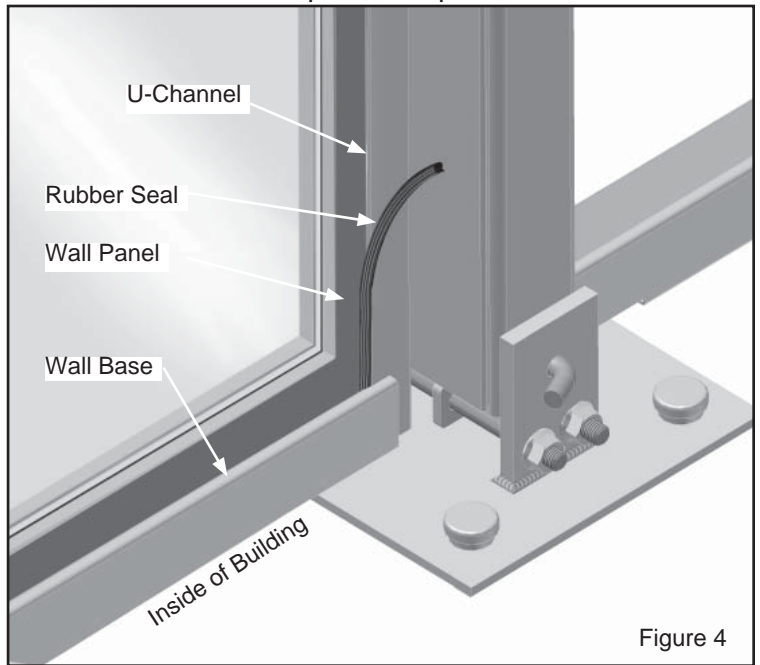

Figure 4



PHONE NUMBER
812- 867- 2421

FAX NUMBER
812- 867- 0547

Anchor products are of superior design and operate best within the parameters of these instructions. It is imperative that the instructions be carefully read and **COMPLETELY FOLLOWED**. Please read installation instructions before the installation or removal of this product. Installation instructions are available online at www.anchorinc.com or by calling 1-800-544-4445.

CAUTION:

1. For each installation, the installer is solely responsible for evaluating the site and the proper securing method determined. Some soils require different staking or securing than that provided with the tent. Due to this variety of soil conditions, these are the manufacturer's suggested sequence of installation procedures. Anchor's responsibility is limited to the manufacture of the tent parts and materials. We are not responsible for methods that installers may choose to erect and secure the tent to the ground.
2. The number of stakes suggested in the installation instructions does not necessarily meet all or any relevant codes on the site of the tent installation. The number of stakes suggested **will, in many cases, keep the tent erected**, however, due to various soil conditions; these stakes will be insufficient **to keep the tent secure in high winds**. It is the tent installer's responsibility, not the manufacturer, to determine the appropriate number of stakes to meet the necessary wind loads on the site. Regardless of the number of stakes we suggest, we make no representation or warranty as to whether this specific number of stakes will meet the local tent code. Anchor does not, nor can it make any suggestions, representation, or warranties about the adequate staking required at each specific installation site. Staking information provided in the installation instructions **is not a suggestion about what is necessary to meet a site-specific load**.

For additional assistance, consult: "The IFAI Procedural Handbook For the Safe Installation and Maintenance of Tentage" and the IFAI Pocket Guide "Pullout Capacity of Tent Stakes", both available from the IFAI Tent Rental Division or on our website.

3. Inasmuch as the weather is unpredictable, good judgment and common sense must be incorporated within installation guidelines. It is the responsibility of the tent installer/maintainer to determine the severity of the weather, proper time and method of installation and/or erection and disassembly. **Note: We recommend that snow and ice be removed from the tent surface as soon as possible because accumulation will damage the tent or fabric structure. Please consult with our Engineering Department about the maximum loads for each product.**

This product has been manufactured for use as a temporary structure. For the safety of all occupants, evacuation is recommended if threatening weather occurs, or if there is any doubt concerning the safe use of this product.

4. Proper safety equipment should be used at all times to insure a safe installation and take down. We suggest a careful evaluation be made to determine safety equipment needed, such as hard hats, steel-toe shoes, safety glasses and other as required. It is our desire that all installations are safe. Please be aware of hidden dangers both underground, i.e., gas lines, water lines, electrical lines, etc. and above the tent such as power lines and telephone lines.
5. Anchor stands behind its products in accordance with its standard Terms and Conditions of sale. A copy of our Terms and Conditions of Sale can be obtained by contacting Anchor at the telephone number and/or address on this document.