

PT 0300 - 1000



RÖDER Zelt- und
Veranstaltungsservice GmbH

Am Lautenstein
63654 Büdingen / Germany

Fon ++49 (0) 6049 700-0
Fax ++49 (0) 6049 700-149
eMail technik@r-zs.com
web www.r-zs.com

ERECTION MANUAL



Copyright: Without our written consent the disclosure, reprinting, copying and reproduction of this publication, whether in full or in part, are prohibited

Index

1 Introduction	4
1.1 General notes	5
1.2 Construction tools	6
2 Straightening of the tent and laying of the base plates	7
2.1 Laying of the base plates.....	7
3 Construction of the tent	11
3.1 Pre-assembly of the legs, beams and wind bracings.....	11
3.2 Mounting of the wind bracings.....	14
4 Erection of the tent	17
4.1 Putting up the first bay (without portal beams)	17
4.2 Putting up the bay (with portal beams)	19
4.3 Erection of the gable supports (not for 3m & 4m tents).....	21
5 Mounting of tent's covers	23
5.1 Pulling up the roof cover.....	23
5.2 Pulling up the sides- and gable covers	25
5.3 Pulling in the gable covers (gable triangles)	26
5.4 Mounting of the ground rail (if provided).....	26
6 Dismantling	30
7 Service notes	31
7.1 Construction of the tent	31
7.2 Bedding and transport	31
7.3 Routine visual inspection.....	31
8 Ratings	32
8.1 Construction of the tent	32
8.2 Tent covers	33
8.3 DIN ISO Normen	33

1 Introduction

The following instructions describe in a methodical plan the construction and erection of your **RÖDER** tent.

Follow always these instructions.

Work from point to point.

If it is necessary, they are extra points, in which you have to take care or pay special attention.

Please pay attention to the appropriate safety regulations for prevention of accidents.

Regarding the contents of this document:

The drawings are made to show clearly the construction and dismantling procedures and also for the identification of the separate building components.

It has to be pointed out that the pictures, do not always correspond to the real dimension and size. Explanations and/or notes have been added to these pictures.

If you have any questions, please call
RÖDER Zelt- und Veranstaltungsservice GmbH in Germany on follow numbers:
Phone ++49-6049-700 - 0 Fax ++49-6049-700 - 339

1.1 General notes

Before starting construction you must read this documentation exactly. If the points are clear and the building components are identified and ready, then start construction and follow the instructions step by step.

Pay attention to the safety regulations for prevention of accidents.
The life of the helpers may be in danger due to the lack of knowledge and poor observation of the given regulations.

Work on every point of the instruction chronologically.

For the construction of the tent there has to be a minimum of 4 people.

Notes on safety:

The joining of the ropes has to be stretched after mounting.

The taking out of the ropes is not allowed.

Use the supplied construction tools for the installation.

Pay attention to the pins, that they are fixed solid after mounting.

Pay attention to the purlins and to the intermediate purlins to erect them always correctly.

During mounting wear protective clothing according to your work to prevent injuries.

Replaced used or damaged components with original new ones.

Pay attention to:

You have to keep the relevant safety appliances and standard specifications.
(Employer's liability insurance association).

The construction helpers have to be instructed about the possible dangers before construction begins.

The supervision and the responsibility has to be taken by an expert person during the construction.

Expert is the person who knows about the operating cycle and the requisite safety precautions.

1.2 Construction tools

The construction and dismantling has to be done with the respective construction tools.

Every delivery includes a mounting rod.

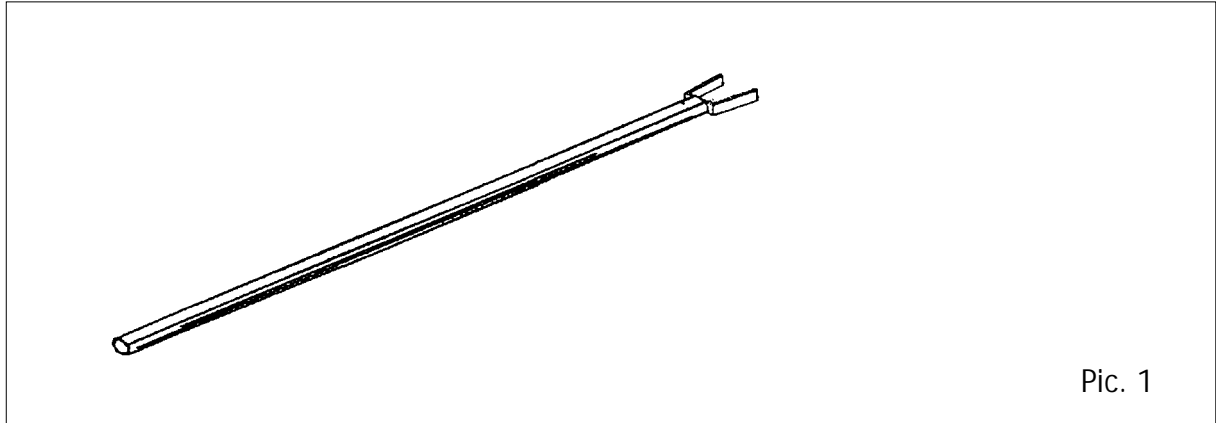

More construction tools and working substance prepared for the structure:

Make your mounting easier by preparing follow constructions tools:

At least 3x traction cable with carabine swivel (at least 250 daN carrying force)

2x double ladder equivalent the height of tent's side

2x spanner or ratchet SW 17

1x handspike

1x aboutsledge

1x pincers

1x measuring tape 15 m

1x directional cord (at least double the length of the tent)

1x optional: peg puller (for dismantling recommended)

2 Straightening of the tent and laying of the baseplates

The main topology of the tent has to be straighten locally (e.g. road course, front of houses etc.).

It has to be carefully and exactly positioned, by laying and straightening of the baseplates. The wrong placing of the baseplates will incur difficulties to the whole construction procedure.

Prepared assembling auxiliaries:

Construction tools:	Building components:
Measuring rod	All the provided baseplates
Measuring tape	For every baseplate equivalent number of earth-anchors
Directional cord	For every baseplate a baseplate pin
Aboutsledge	

2.1 Laying of the base plates

Identify and assign the components according pic. 3.

Note: Do not beat in the earth-anchors all the way, leave about 5 cm providing for adjustment.

2.1.1 Choose a front orientation.

2.1.2 Stretch the directional cord (tent's length + 2m each side).

2.1.3 Adjust 1. baseplate parallel to the directional cord of the right angle and fix it with the 2 earth-anchors. (Do not beat in the earth-anchors all the way).

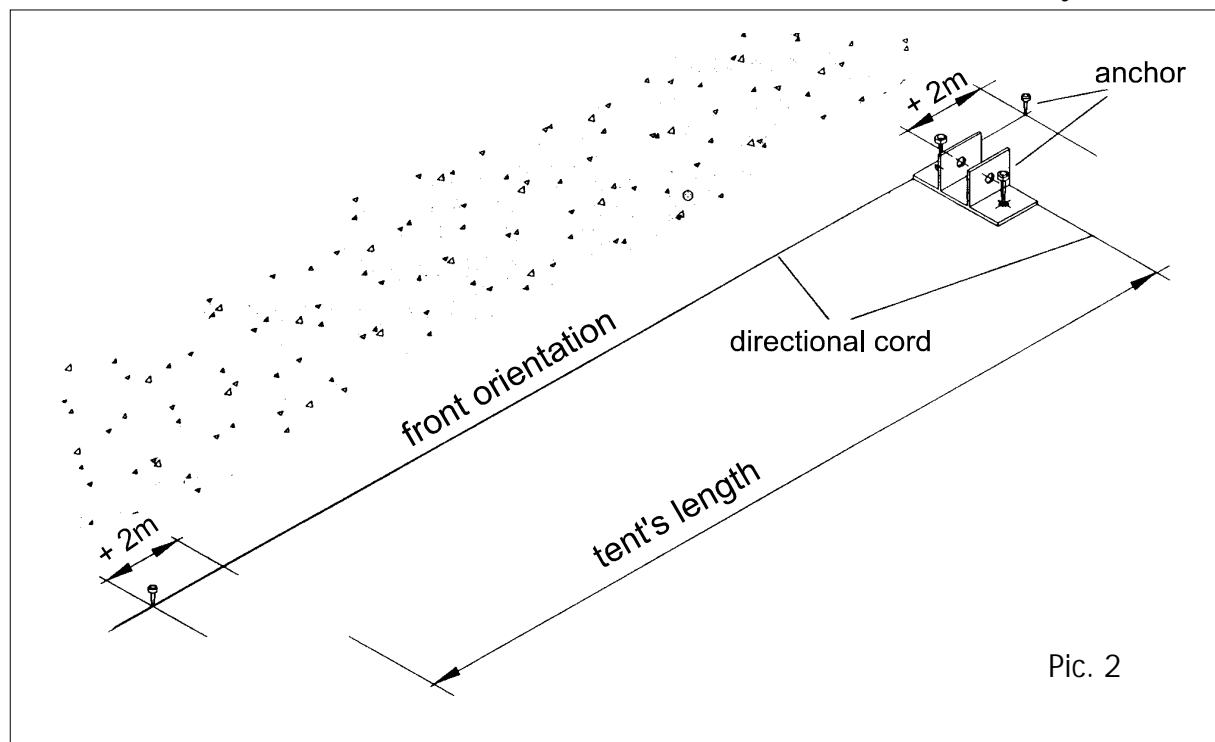

- 2.1.4 Stretch the directional cord across the tent's width and adjust it by estimating sight to right angle.
- 2.1.5 Measure the tent's width from the middle of the baseplate **1** until the middle of the baseplate **2** adjust the baseplate parallel to the directional cord and fix them tightly with 2 earth anchors (pic. 3).
- 2.1.6 Lay parallel the baseplate **3** to the directional cord for the tent's length. Measure exactly 3,0 m from the middle of baseplate **1** until the middle of baseplate **3** and fix tightly the baseplate **3** with 2 earth anchors.
- 2.1.7 According the picture measure exactly 3,0 m between baseplate **1** and baseplate **2** and mark it (point B). Measure exactly 4,0 m between the baseplate **1** and baseplate **3** and mark it (point A) (pic. 3).
- 2.1.8 There ought to be a diagonal of 5,0 m between the points A and B (pic. 3). You have to place the directional cord in a way that between the baseplates **1** and **2** the dimension is 5,0 m.
- 2.1.9 Adjust baseplate **2** too and align it to the directional cord. Check again the width of the tent between the baseplate **1** and baseplate **2**. Fix tightly the baseplate **3** with 2 earth anchors.
- 2.1.10 Align the baseplate **4** parallel to the directional cord for the tent's length. Measure exactly 3,0 m between the middle of the baseplate **3** and the middle of the baseplate **4** and fix tightly the baseplate **4** with 2 earth anchors.
- 2.1.11 Repeat the above points until all the baseplates of the tent's side have been fixed tightly.
- 2.1.12 Lay the baseplates of the opposite side to the baseplate **2**, and fix them tightly with earth anchors.
- 2.1.13 Finally check the tent's dimensions among the middles of the outer baseplates.

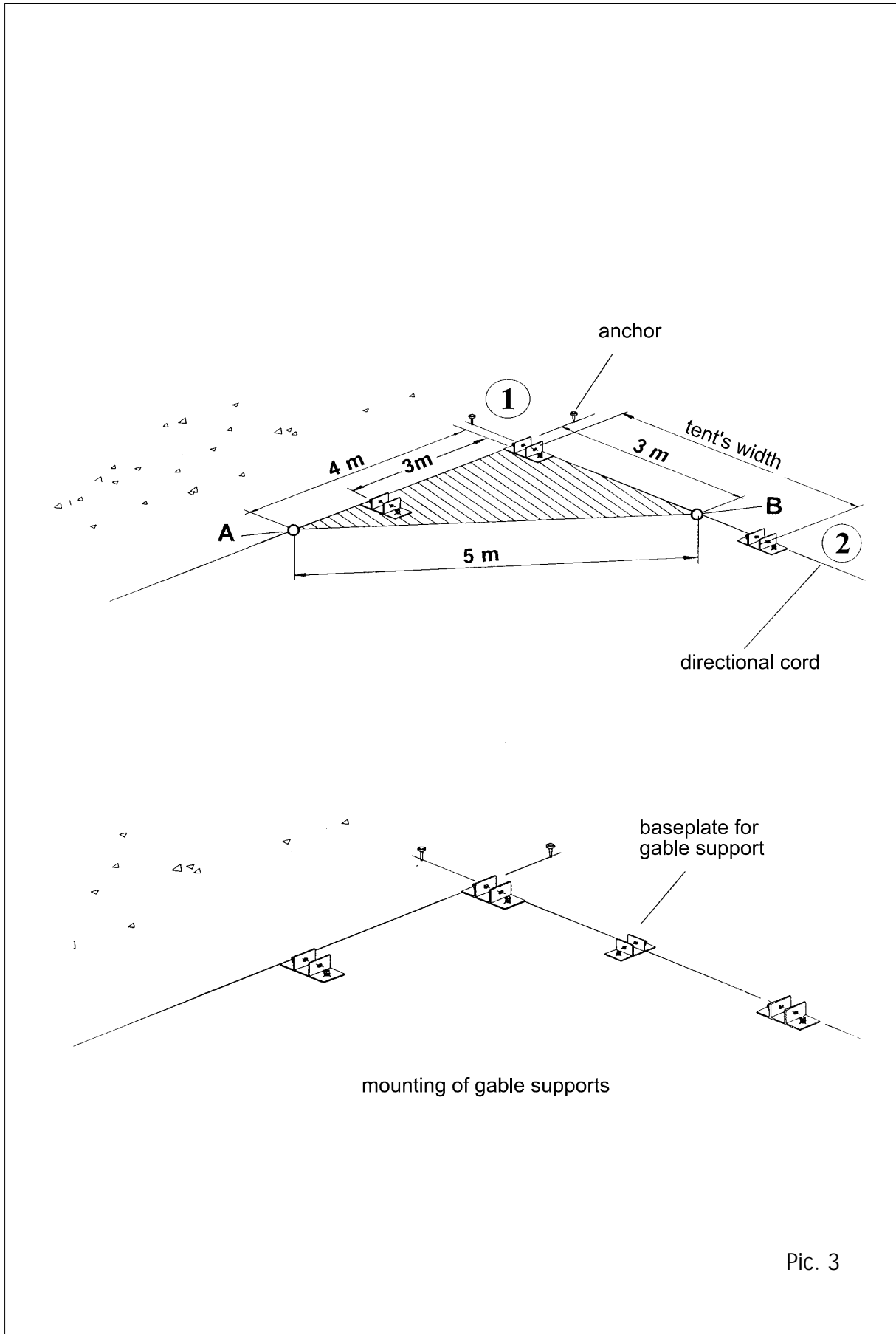

Pic. 3

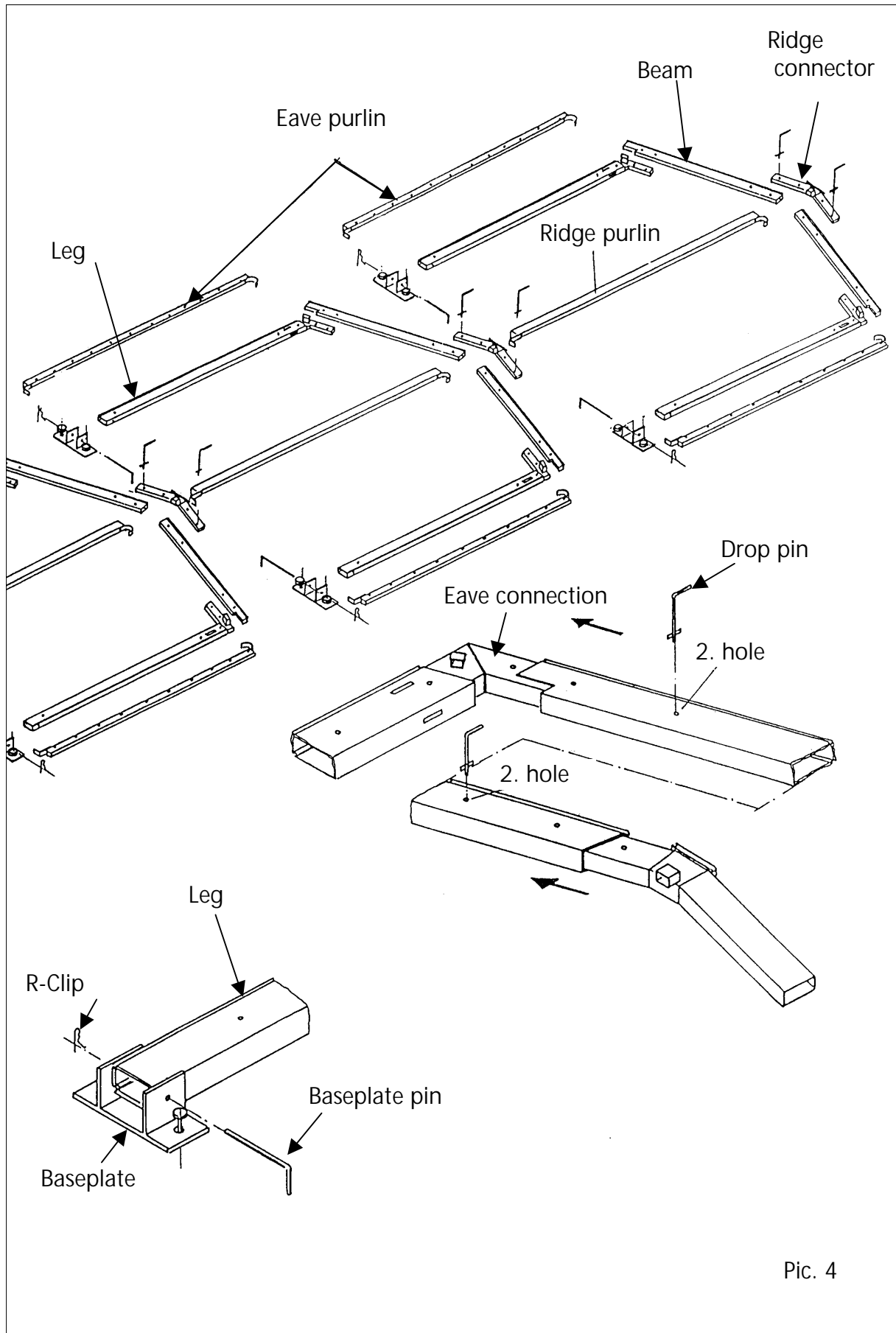

Pic. 4

3 Construction of the tent

3.1 Pre-assembly of the legs, beams and wind bracings

Prepared assembling auxiliaries:

Construction tools:

Squared beams

Crowbar

Building components:

Beams

Legs

Ridge connectors

Pins

Equivalent number of wind bracings (see 3.2)

Intermediate purlins (see table)

Ridge purlins

Eave purlins

Gable supports (see table)

Gable eave rails

Table of the gable supports and intermediate purlins:

Tent width	Gable supports each gable side	Intermediate purlin each field
3 m	0	0
4 m	0	0
5 m	1	1
6 m	1	1
8 m	1	1
9 m	2	3
10 m	2	1

Mounting of the legs and beams

Identify and assign all the components according to the pic. 4 and 5.

The components are according to the pictures. On placing proceed as follows.

- 3.1.1 Push each of the left and right beam in to the ridge connector and bolt them with pins.
- 3.1.2 Place the beams to the equivalent eave connection receivers to the legs and bolt them with pins.
- 3.1.3 Place the bays (mounted legs and beams) in to the baseplates and bolt them with baseplate pins. Fix them tightly with a R-clip. (Pay attention to the boring of the baseplate pin for the R-clip is facing to the outside of the tent. Important for the erection of the gable eave rails).
- 3.1.4 Lay and place the gable supports and gable eave rails to the endbeam.
- 3.1.5 Lay and place the intermediate-, ridge- and eave purlins.

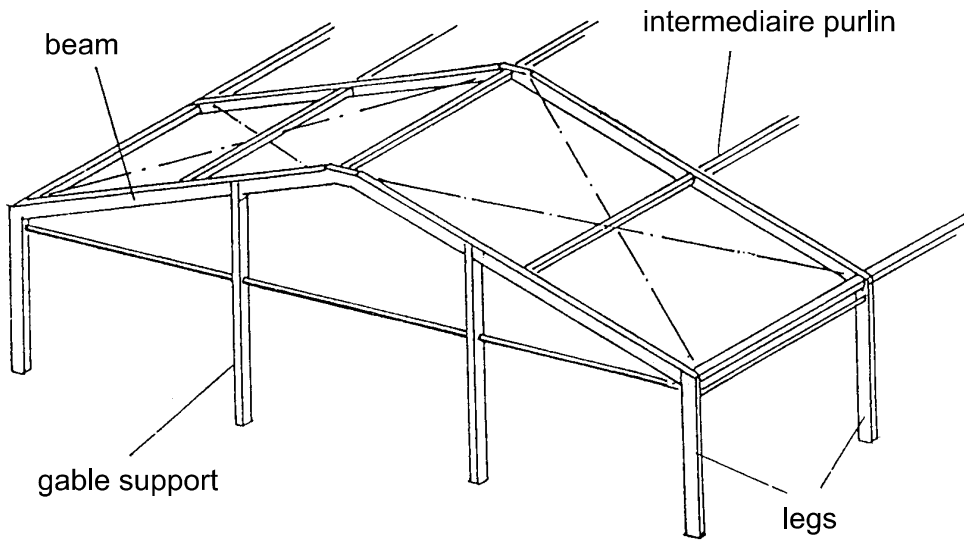

Example of a 10m tent with 2 additional gable supports

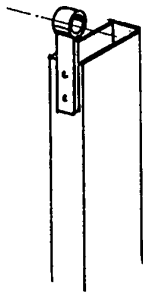

fixing of gable supports for tents of 5m, 6m and 8m

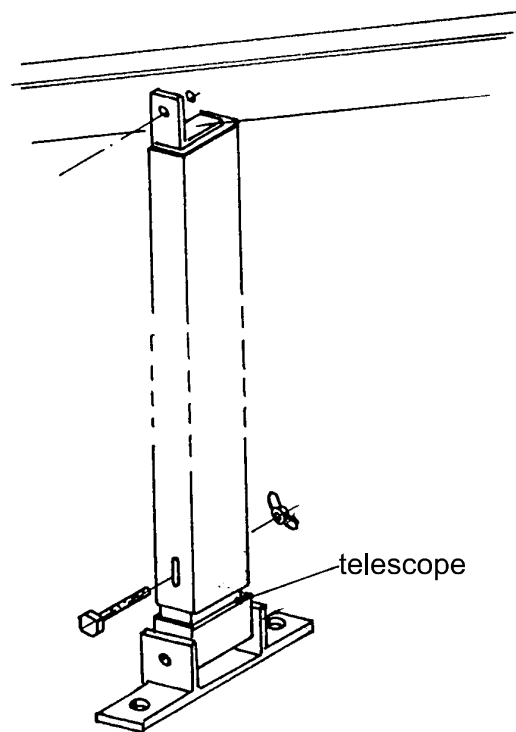

Pic. 5

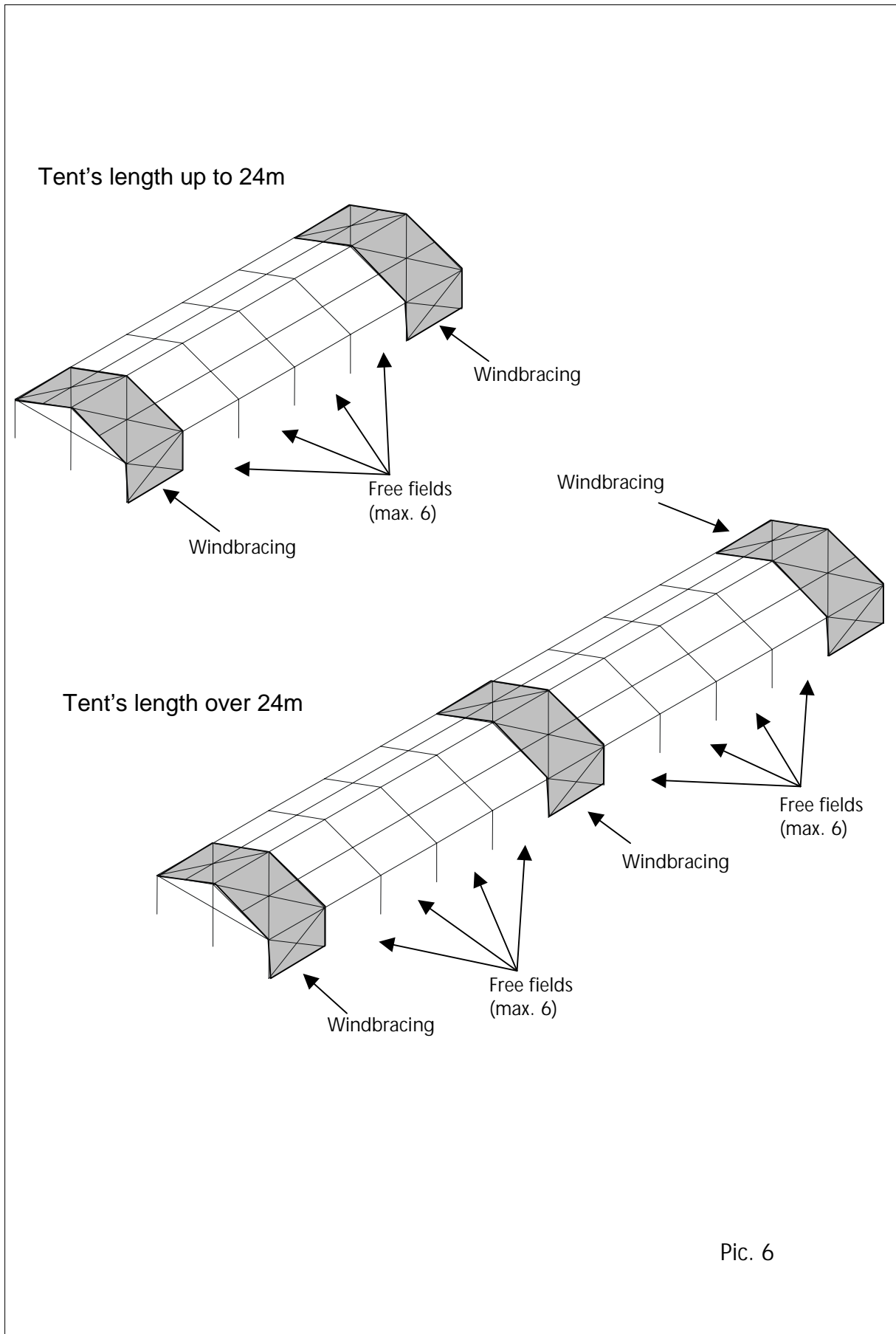

Pic. 6

3.2 Mounting of the wind bracings

Mount the wind bracings (pic. 6).

Do not move them out.

Mount each of the wind bracing to the first and to the last field of the tent.

The wind bracings have connection wires to the roof bond and brace crosses to the walls. In place of the brace crosses the portal beams can be used.

They must not be more than 6 free fields between the bracings.

If more than 6 free fields are put, then an additional wind bracing has to be mounted.

See the picture 6 for the mounting of the brace fields.

In principle:

The wires of the wind bracings have to be mounted in a way that the toggle-type fasteners are always set at the bottom part of the wire.

By the pre-assembly the roofing bonds have to be fastened only to a bay.

3.3.1 Prepare the wires of the wind bracings, accord. pic. 7, to the equivalent fields.

3.3.2 Screw on the toggle-type fasteners of the side (do not screw them on all the way). Unhook the shackle.

3.3.3 Mount the ring bolts of the roof bonds to the ridge connectors and pull them tightly (pic. 7).

3.3.4 Insert from above the ring bolts to the endbay and place from below the nut, insert from below the ring bolt to the middle bay and place from above the nut. Unhook the shackle (pic. 7).

3.3.5 Mount the crosses of the wind bracings to the first bay. Dismantle the hexagon bolts with nuts and screw them on to the equivalent borings (pic. 8). (This point is cancelled by erecting of a portal beam. See the point 4, erection of the tent).

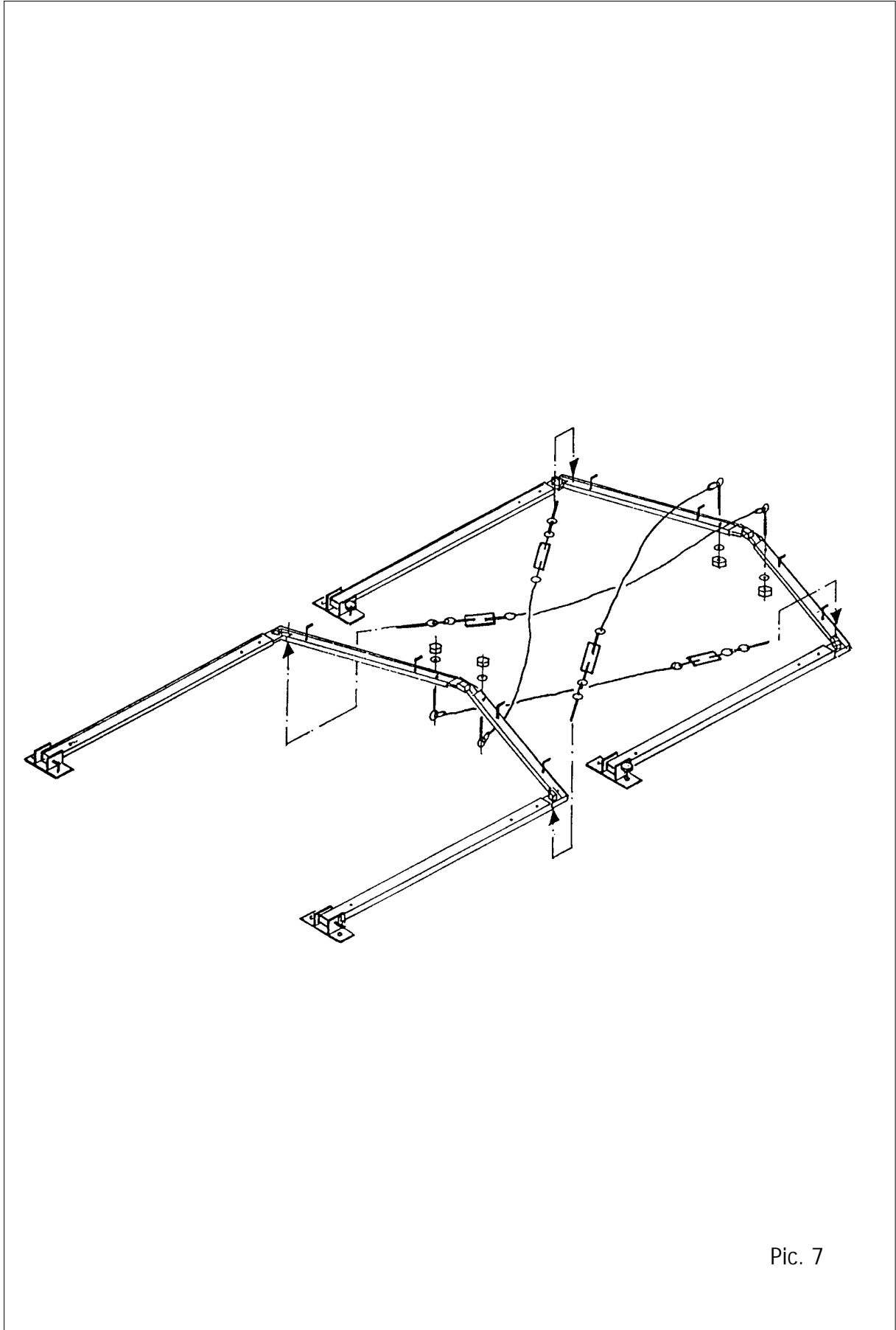

Pic. 7

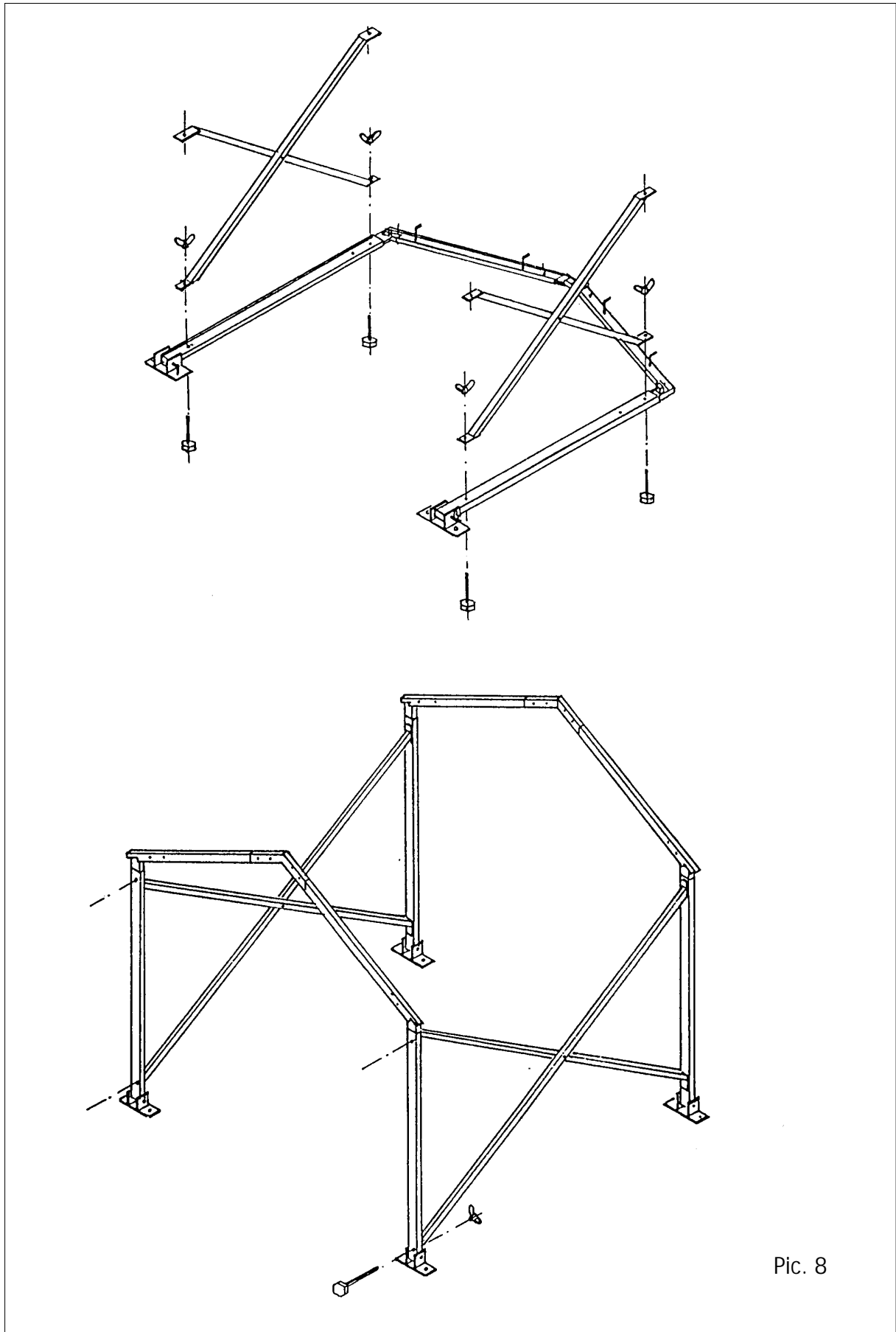

Pic. 8

4 Erection of the tent

4.1 Putting up the first bay (without portal beams)

- 4.1.1 Put up the mounted bay with the crosses of the wind bracing. One person is fixing tightly the bay to the legs (pic. 8).
- 4.1.2 Place vertical the second mounted bay (pic. 8).
- 4.1.3 Mount the crosses of the wind bracing of the first bay to the hexagon bolts and nuts to the second bay.
- 4.1.4 Hang each eave purlin with the RADIUS hooks of the tent's left and right side (pic. 10). Pay attention to the borings of the eave purlins, that they are facing to the inside of the tent (pic. 10).
- 4.1.5 Hang up the eave purlins to the 2. bay. You can use the mounting fork.
- 4.1.6 Hang up the ridge purlin with the RADIUS hooks.
- 4.1.7 Hang up the ridge purlin with the angles to the second bay. You can use the mounting fork.
- 4.1.8 If provided, hang up in the same way the intermediate purlins to the ridge- and eave purlins.
- 4.1.9 Hang up the wind bracings of the roof to the second bay and distort the toggle-type fasteners. (Take care during working on the double ladder).
- 4.1.10 Repeat the points 4.1.2, 4.1.4 until 4.1.7 for the erection of the rest bays. Repeat the points 4.1.3 and 4.1.8 for the next wind bracing.

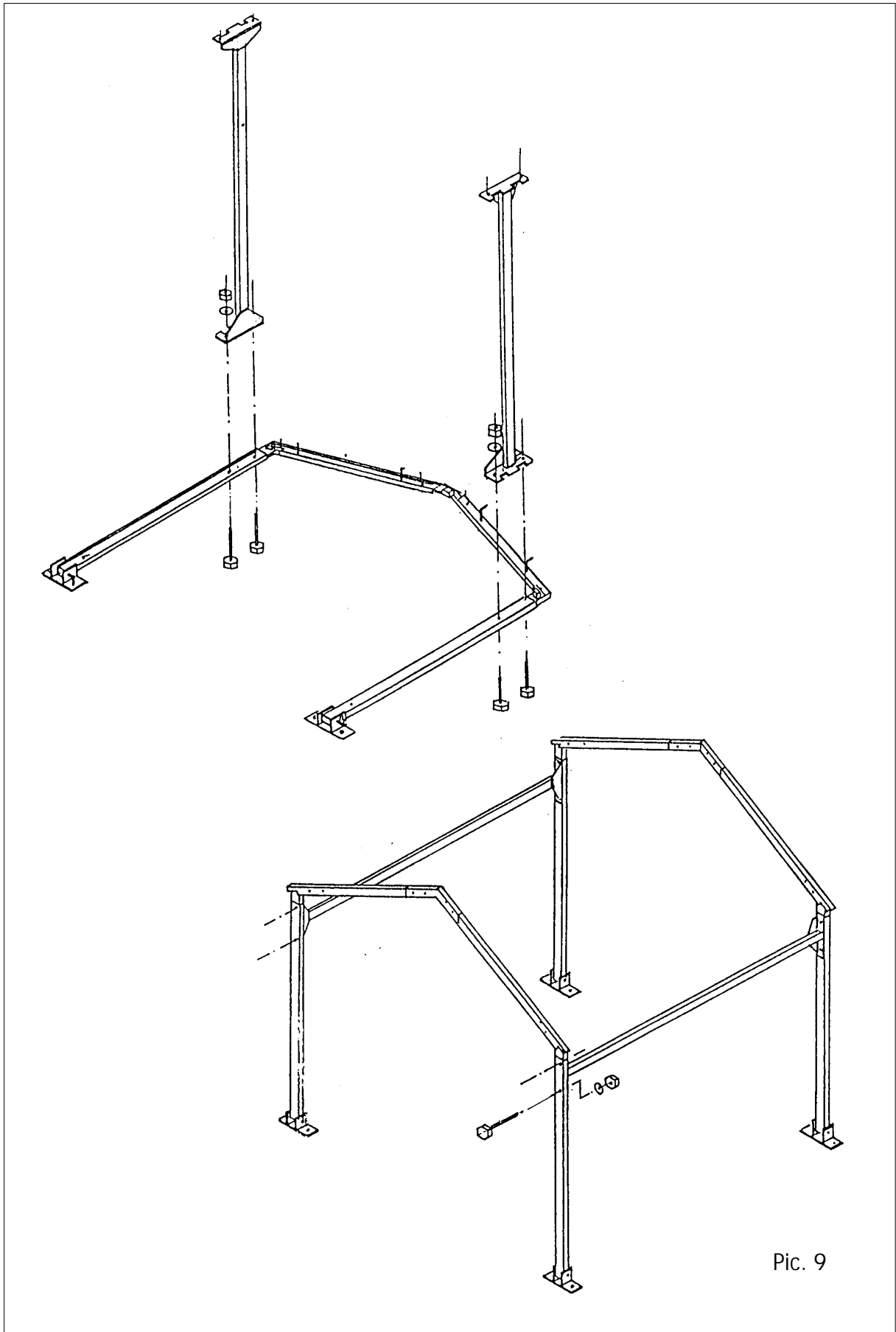

Pic. 9

4.2 Putting up the bay (with portal beams)

- 4.2.1 Put up the mounted bay. A person is fixing tightly the bay to the legs (pic. 9).
- 4.2.2 Place vertical the second mounted bay.
- 4.2.3 Screw on the portal beams between the legs to each equivalent positions (pic. 9).
- 4.2.4 Hang up each eave purlin with the RADIUS hooks of the tent's left and right side. Pay attention that the borings of the eave purlins are facing to the inside of the tent (pic. 10).
- 4.2.5 Hang up the eave purlins with the angles to the second bay. You can use the mounting fork (pic. 10).
- 4.2.6 Hang up the ridge purlin with the RADIUS hooks.
- 4.2.7 Hang up the risge purlin with the angles to the second bay. You can use the mounting fork.
- 4.2.8 If provided, hang up in the same way the intermediate purlin to the ridge- and eave purlins.
- 4.2.9 Hang up the wind bracings of the roof to the second bay and disort the toggle type fasteners. (Take care during working on the double ladder) (pic. 11).
- 4.2.10 Repeat the points 4.2.2, 4.2.4 until 4.2.7 for the erection of the rest bays. Repeat the points 4.2.3 and 4.2.8 for the next wind bracing.

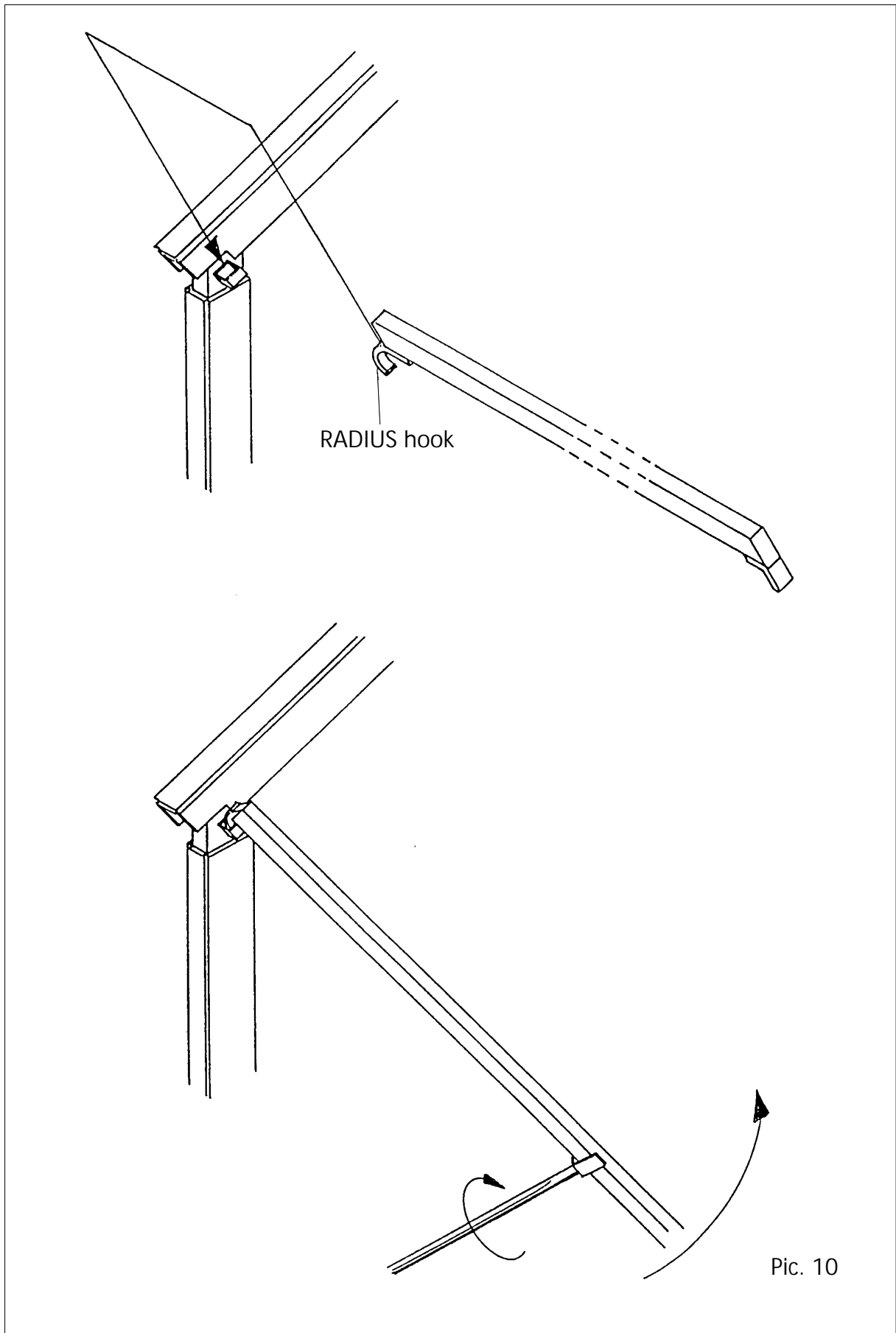

4.3 Erection of the gable supports (not for 3m & 4m tents)

Note:

There are additional gable supports for the modles of party tent 5m, 6m, 8m, 9m and 10m.

Model party tent 5m, 6m & 8m:

- 4.3.1 Place vertical the gable supports under the ridge connectors of each end bay and feed them into the receivers of the ridge connectors (pic. 5).
- 4.3.2 Place the safety pin and fixed it tightly with a R-clip.
- 4.3.3 Place the gable supports into the baseplate and pay attention to the gable support that is standing vertical and the baseplate is on the ground.
- 4.3.4 Fix the baseplate tightly with 2 earth anchors.

Model party tent 9m & 10m:

- 4.3.5 Every gable side has 2 gable supports for mounting. Lay the gable supports to the equivalent end bays (pic. 5).
- 4.3.6 Screw on with hexagon bolts from outside the gable supports to the equivalent positions of each end beam.
- 4.3.7 To avoid the differences of the height, the gable supports are provided with telescopes. Remove the hexagon bolt and set the telescope accordingly.
- 4.3.8 Place the gable supports to the baseplates and pay attention to the gable supports that they are standing vertical and the baseplates are on the ground.
- 4.3.9 Fix the baseplates with 2 earth anchors.

Hang on 2 wires and
pull them back

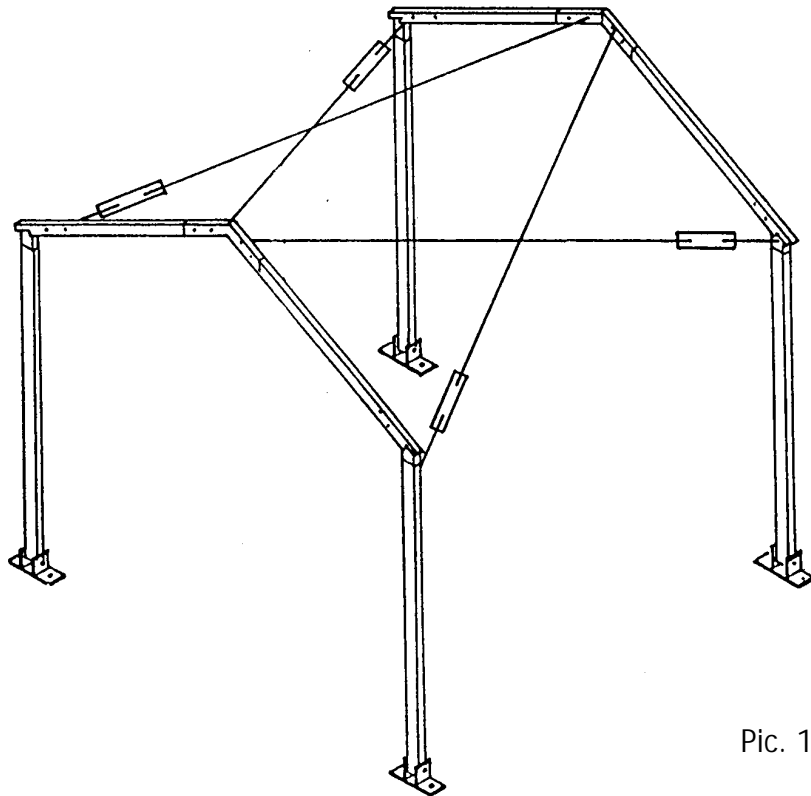
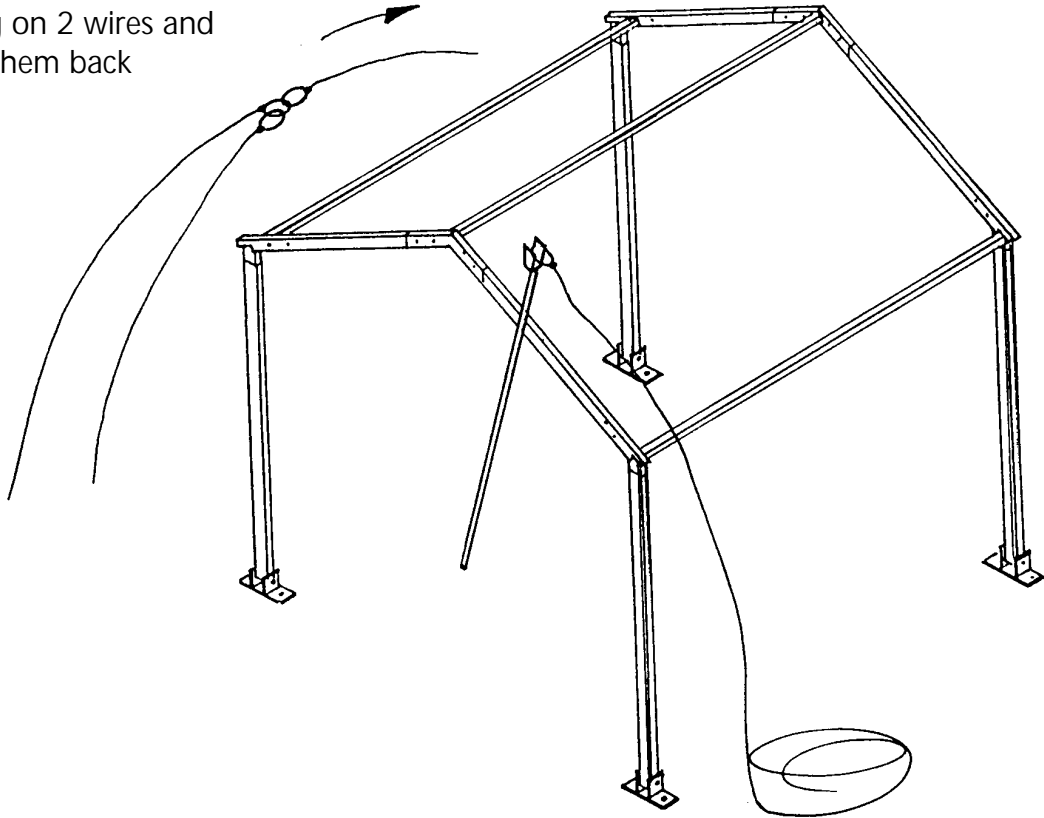

Pic. 11

5 Mounting of tent's covers

Before starting the mounting of the tent's covers, all earth-anchors have to be beaten in and the wind bracings tightened (compare point 4).

Do not try to pull the cover with force. If there is any heavy resistance, pull back another time and try again.

Prepared assembling auxiliaries:

Construction tools:

3x traction cables with carabine

2x leading-in conductor for covers
mounting rod

Building components:

All the roof covers

5.1 Pulling up the roof cover

- 5.1.1 Throw a traction wire from left to right over the ridge of the first brace field. (pic. 11). You can use the mounting fork.
- 5.1.2 Pull with this wire two more traction wires over the ridge.
- 5.1.3 Place to the right position respective roof covers (pic. 12).
- 5.1.4 Hang up both of the traction wire with the carabine hooks to both of the outer traction eyes of the roof cover. Hang up the 3. traction wire to a traction eye (pull back rope) (pic. 12).
- 5.1.5 Lift the roof cover to the height of the keder grooves through lifting from the opposite side of the tent to the traction wires, and feed in the left and right keder of the cover into the keder groove of the roof beam (pic. 12).
- 5.1.6 Pull the two of the traction wires at the same time the roof cover into the roof beam. Pull the cover slowly over the ridge.
- 5.1.7 After the setting of the cover into the roof beam, the traction wires will be removed and hang up to the 3. traction wire, which has been pulled in with the cover over the ridge. The traction wire will be stretched back in a way that both of the other traction wires can be placed again to the start position.
- 5.1.8 Repeat the points 5.1.1 until 5.1.7 for all the roof covers.
- 5.1.9 After the pulling of the roof covers into the beams, the S-hooks of the cord tensioning of the roof cover will be hang up from the insides tot he borings of the eave purlins (pic. 13 & pic. 12).
- 5.1.10 Last check to the position of all the roof covers.

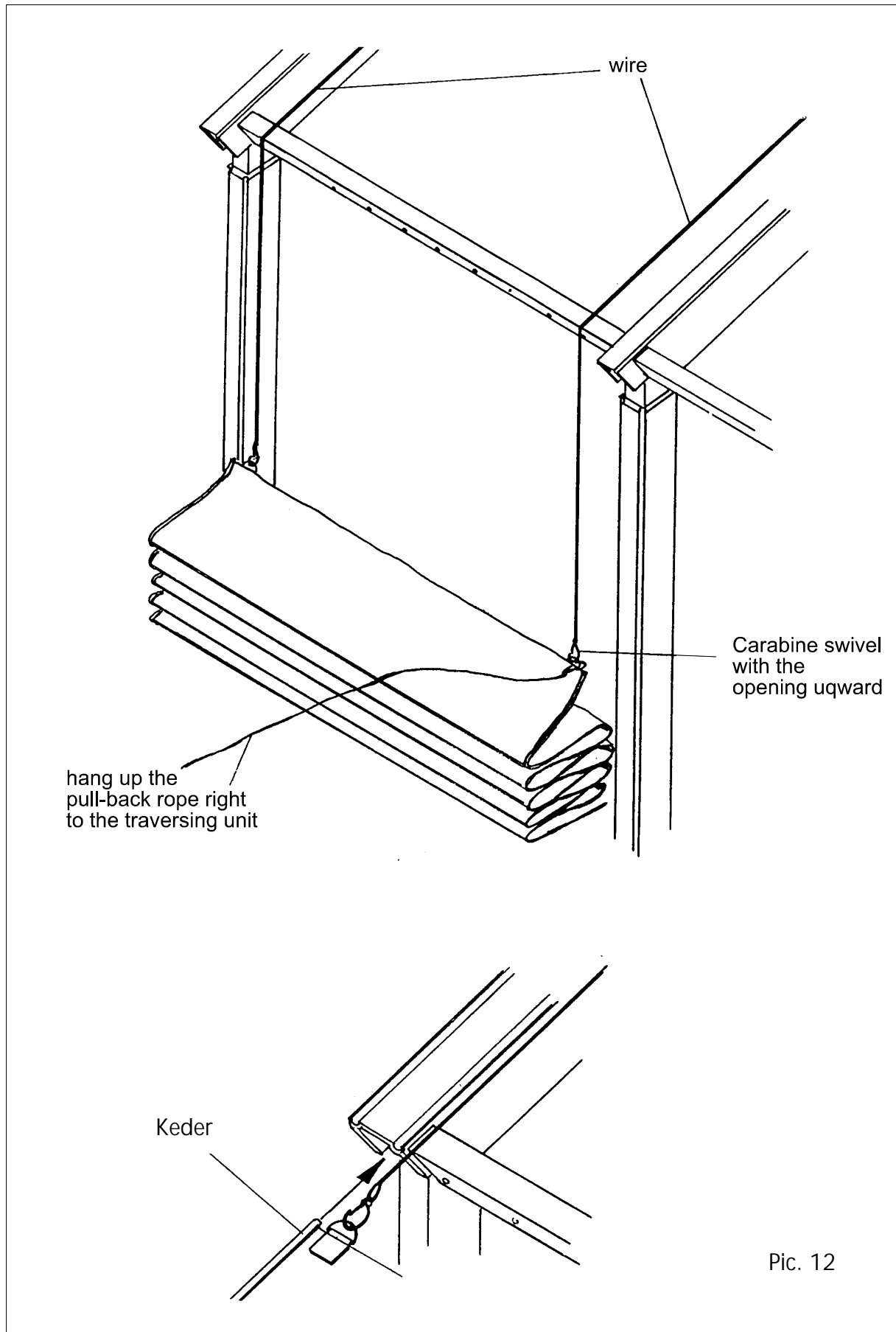

5.2 Pulling up the sides- and gable covers.

The sides- and gable covers have loops and eyes and they have to be placed across the tent length to the gable sides (pic. 13).

The covers will be mounted to keder grooves of the legs and to a curtain rail.

- 5.2.1 Allocate and lay the covers. Each line with the rings is laying upwards.
- 5.2.2 Place upwards the keder of the roof side to the spring of the tent's legs and push it fully upwards.
- 5.2.3 Place in the same way the below half of the cover and push it fully below.
- 5.2.4 Mount in the same way the belonging 2. cover (loop- and eye side) according to the points 5.2.2 and 5.2.3.
- 5.2.5 Push the curtain rail through the rings of the side covers and hang on the curtain rail into the receivers of the eave connections. If the tent is provided with gable supports, then hang on the curtain rails of the gable sides to each equivalent receiver of the gable supports (pic. 13).
- 5.2.6 Cord up both of sides, resp. gable covers from top to the bottom. Feed the 1. loop through the first eye, then the second loop firstly through the second eye then through the first loop. Cord up in the same way all loops and eyes. Bind the last loop.
- 5.2.7 Repeat for all the sides- and gable covers the points 5.2.2 until 5.2.6.

5.3 Pulling in the gable covers (gable triangles)

Each cover of the tent gable has 2 gable covers, a loop side and a eye side. The inside of the covers is marked with the loops, resp. the overlay of the sides which are turning down, bond and making an angle.

The outside is marked through **RÖDER** (if provided) and / or colour lines (if provided).

- 5.3.1 Feed the gable triangles with the keder to the top keder groove of the end beam and pull it until the gable middle with the help of the mounting fork (pic. 14).
- 5.3.2 Cord up to the inside of the tent from the top to the bottom both of gable covers according the point 5.2.6. Bind the last loop (pic. 14).
- 5.3.3 Lay to the curtain rail the belts or bur bands, which are on the below edge, and bolt them.
- 5.3.4 Repeat the points 5.3.1 and 5.3.2 for the opposite gable side too.

5.4 Mounting of the ground rail (if provided)

The ground rails for the sides- and gable covers are provided by **RÖDER** as an accessory.

- 5.4.1 Feed the ground rails into the ground rails kits of the side curtains (pic. 15).
- 5.4.2 Push the ground rails on to the flange pin and secure them with a R-clip.
- 5.4.3 Feed the ground rail for the gable cover into the ground rail kit.
- 5.4.4 Hang up the ground rail to the bolt receiver of the ground rail holding plate of the outer baseplate and fix it tightly with a R-clip.

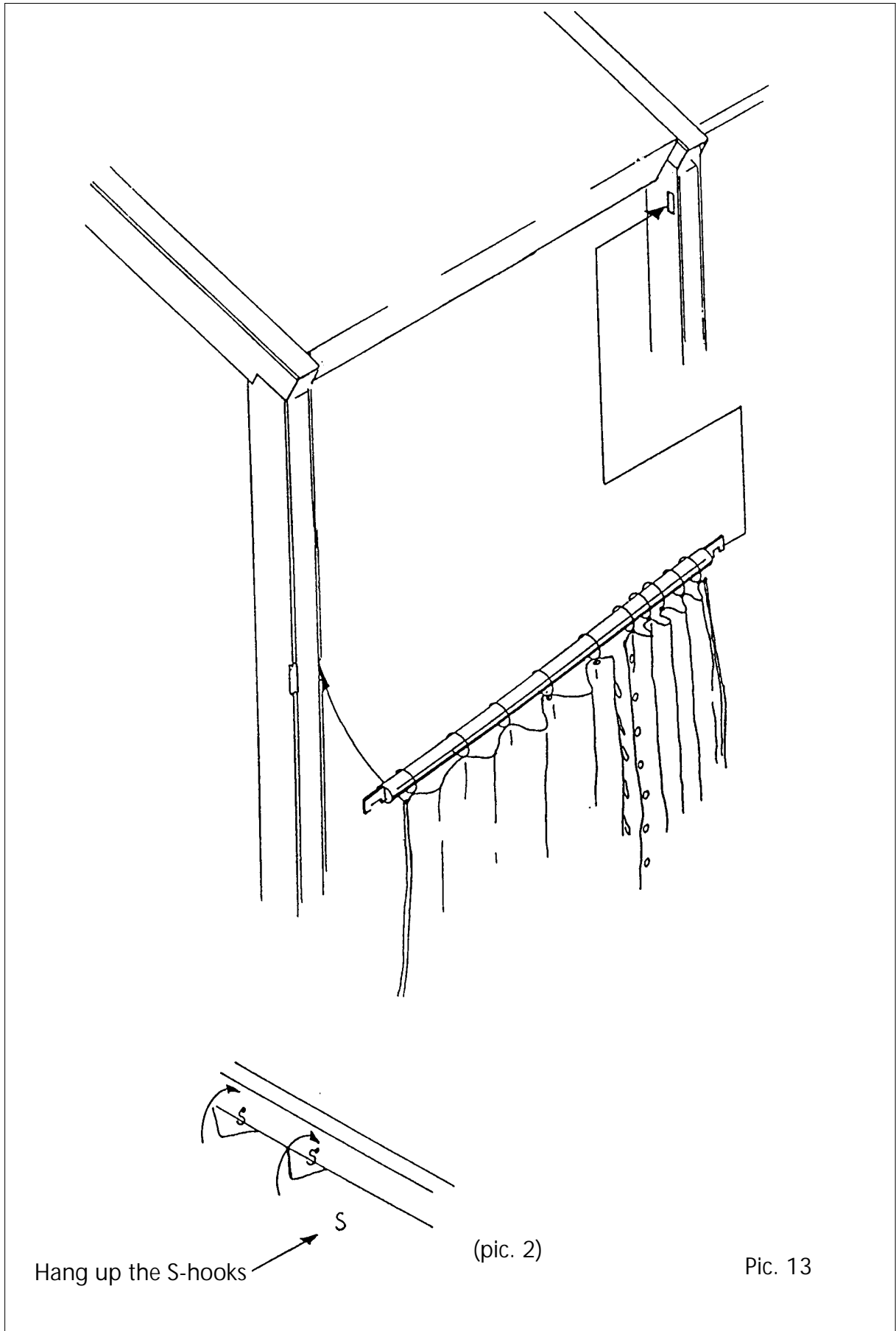

Hang up the S-hooks

(pic. 2)

Pic. 13

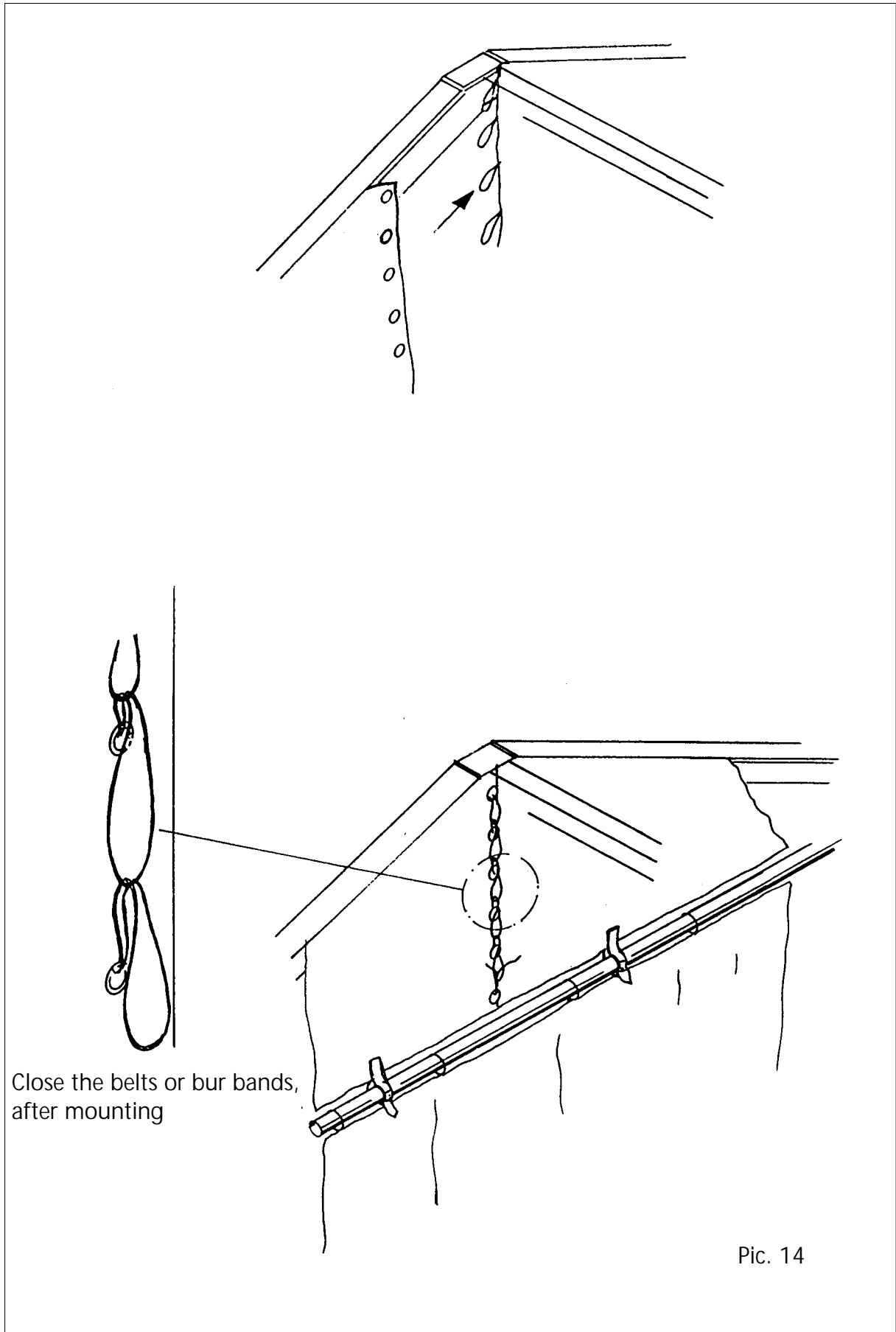

Close the belts or bur bands,
after mounting

Pic. 14

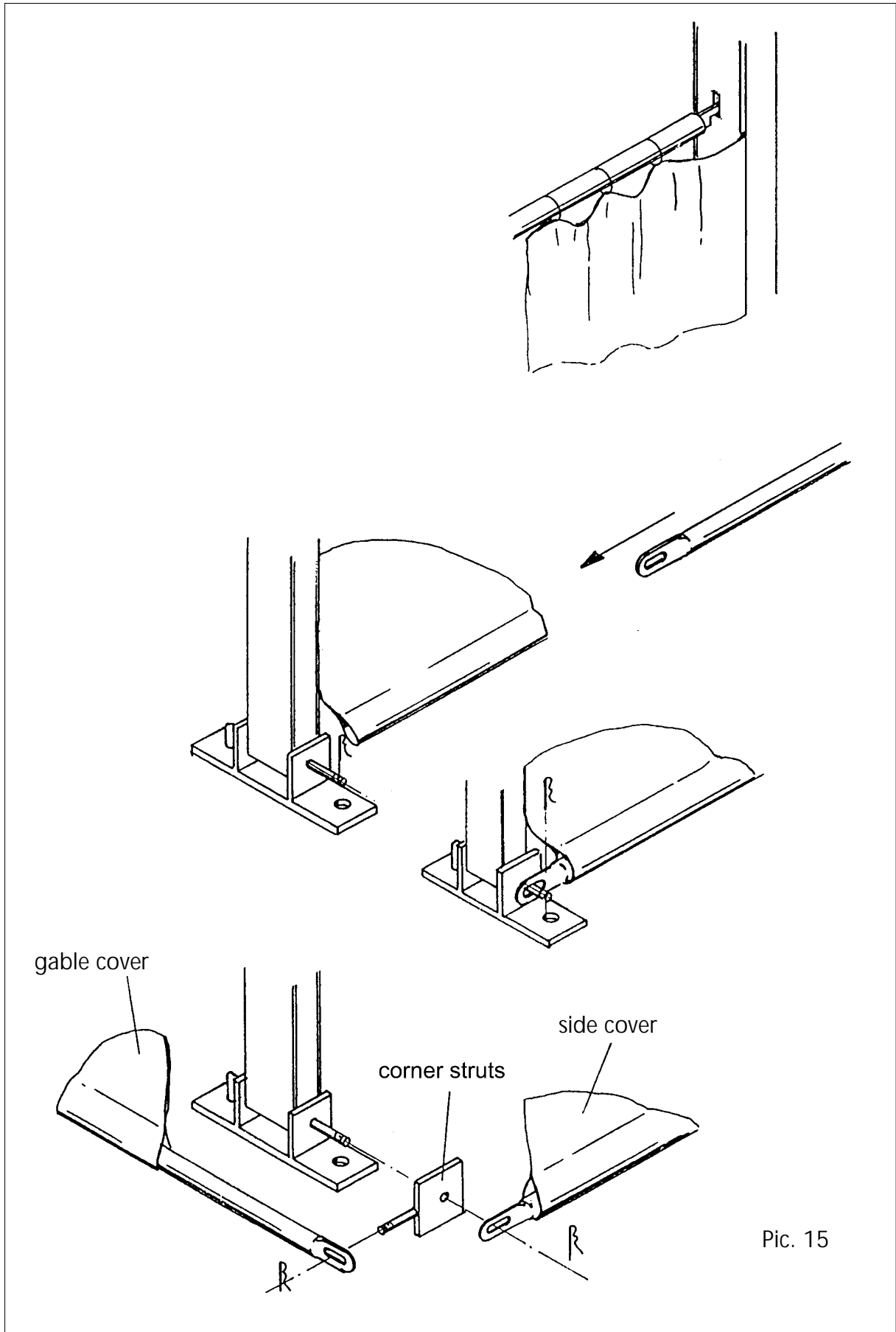

Pic. 15

6 Dismantling

For the dismantling of the tent you have to follow the instructions in reverse to the construction.

The principle of dismantling:

All the covers of the tent ought to be **dry** before you start folding.

After dismantling you have to mark, sort and load all the building components immediately.

- 6.1 Dismantle the ground rails.
- 6.2 Unhook the sides- and gable covers, lay them on a protect foil and fold them.
- 6.3 Undo the gable cover, lay it on a protect foil and fold it.
- 6.4 Undo the bracing of the roof cover.
- 6.5 Remove the roof wires to the eave purlins.
- 6.6 Undo the roof cover, lay it on a protect foil and fold it.
- 6.7 Loosen the crosses resp. the portals of the first field.
- 6.8 Unhook the purlins of the first filed and lay them down.
- 6.9 Lay down the first bay.
- 6.10 Undo the bays of the beams, legs and ridge connectors.
- 6.11 Dismantle in analogy all the rest of the bays.
- 6.12 Pull the anchors.

7 Service notes

7.1 Construction of the tent

- 7.1.1 The restretching of the wind bracings, treaded bolt connections and roof racings is requisite:
- every 3 months (stand-by time)
 - after hot periods
 - after a strong gale
- 7.1.2 Pay attention to the earth-anchors, that is deep seated in a solid position.
- 7.1.3 Check for deformation or damage.
- 7.1.4 If there are any damaged parts, then change them immediately with new original spare parts.

7.2 Bedding and transport

To avoid damage to the aluminium profile you have to bed and to transport all the aluminium profiles on a smooth area (e.g. **RÖDER** transport units) and you have to pay attention to the profile, that stand out on the smaller profile side.

7.3 Routine visual inspection

Periodically carry out a visual inspection after every use (e.g. after every event day):

The inter- and eave purlins have to be hung up according to the rules.

The bolt- and pin connections have to be inspected.

Dirty covers have to be cleaned (the washing can take place in our own **RÖDER** laundry).

8 Ratings

8.1 Construction of the tent

All the dimensions have been given axial

Tent's length:	min. 6,0 m
Max. length:	any enlarge in grid possible
Tent's width:	3,00 / 4,00 / 6,00 / 8,00 / 9,00 / 10,00 m
Ridge height:	2,84 / 3,01 / 3,38 / 3,74 / 3,93 / 4,11 m
Side height:	2,29 m
Roof inclination:	20°
Bay distance middle:	3,0 m
Leg profile:	81 x 48 mm
Beam profile:	81 x 48 mm
Ridge purlin profile:	60 x 40 mm
Intermediate purlin profile:	40 x 35 mm
Eave purlin profile:	60 x 40 mm
Material main construction:	aluminium, anodic oxidation
Material connection parts:	steel, zinc
Kind of connection (legs/beam):	plug-type connection
Requisite foundation pressure:	> 0,2 MN/m ² (see static)
Design load: (see static)	wind load 0,3 kN/m ²
Longest piece of part:	6,0 m
Anchorage:	earth-anchor Ø 25 x 800 mm

8.2 Tent covers

Check points		unit	actual value
Material DIN 60001			PES
Yarn notation DIN 53830	linkage body	dtex dtex	1100 1100
Set infabrics DIN 53853	linkage body	Fd/cm Fd/cm	8,00 8,00
Bond			L1/1
Coating			both sides PVC
Coating support DIN 53358		g/m ²	470
GSM substance DIN 53352		g/m ²	650
Tensile strength DIN 53354	linkage body	N/5cm N/5cm	2800 2500
Tear strength DIN 53363	linkage body	N N	300 300
Adherence DIN 53357		N/5cm	100
Weld adherence by 70°C		N/5cm	2400

The quality B 101735 of DIN 4102 B1, M2, BS 3119/3120 has proved that is flame retardent.

8.3 DIN ISO Normen

RÖDER tents have the following DIN ISO standard specifications:

DIN 1054 DIN 1055 DIN 1480 DIN 1808 DIN 3066 DIN 4112
DIN 4113 DIN 4114 DIN 4115 DIN 18800 DIN EN ISO 9004-1