

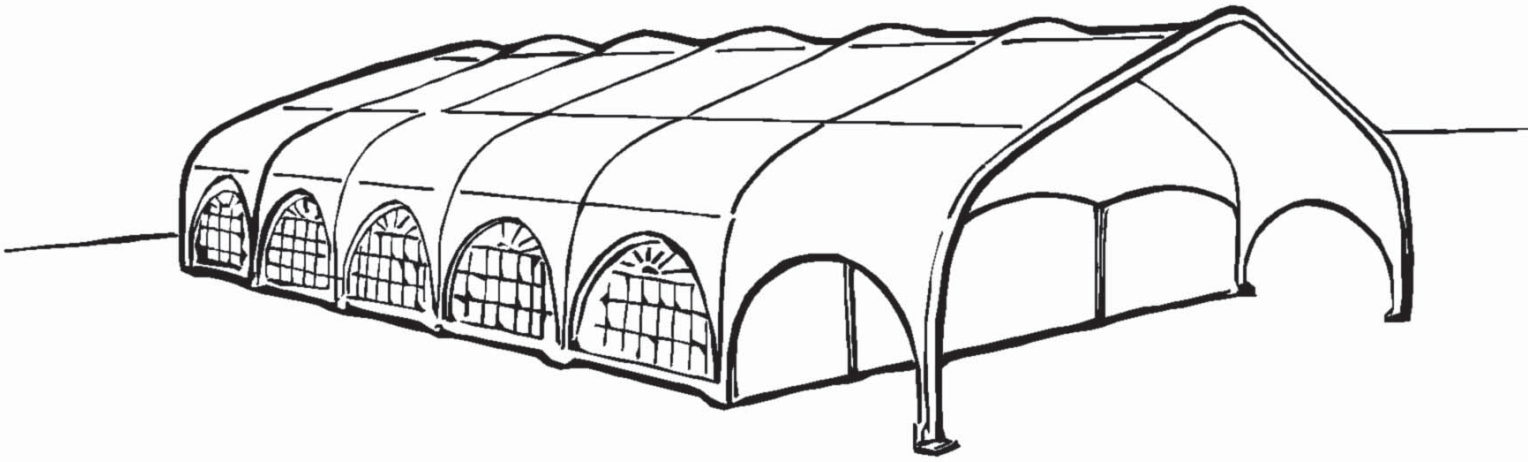

©Anchor Industries, Inc. 1998 • All Rights Reserved

## Clearspan Fabric Structures



# Assembly Instructions

## AA AnchorSpan™

### 30', 40', 50' & 60' Wide



1100 Burch Dr., Evansville, IN 47725  
Ph. 812-867-2421 • Fx. 812-867-0547  
E-mail: [tents@anchorinc.com](mailto:tents@anchorinc.com) • [www.anchorinc.com](http://www.anchorinc.com)  
©Anchor Industries Inc. 2001

# ANCHORSPAN™ AA INSTALLATION INSTRUCTIONS INDEX

<u>Page #</u>	<u>Subject</u>
2	List of Beam and Frame Components and Hardware
3	AA AnchorSpan™ Terminology
4	AA AnchorSpan™ Component Illustrations
5	Introduction
6	Safety Guidelines
7	Equipment and Labor Recommendations for Manual Installation
8	Footprint Layout
9	Hardware Pattern for Beam Joints, SpanLatch™ Purlins and End Uprights
10	Beam Assembly
11	Attaching SpanLatch Purlins and Cross-Cablings
12	The Gin Pole Method and securing the First Beam with Diagonal Braces
13	Erecting Second Beam
14	Latching SpanLatch™ Purlins and Stabilizing with Cross-Cablings
15	Installing the Middle Fabric Panels
16	Mid-Eave Bars
17	Tensioning Middle Panels and Installation of 2-Piece Gabled End Panel
18	Alternate methods for End Installation, Sloped Ends, Installing End Uprights
19	Completing End Framing, Wing & End Eave Bars, Baseplate Adapter Bars
20	Tensioning Gabled End Panel and Customizing for Internal Partitions
21	AnchorSpan™ Wall Systems Illustrated
22	Installing Walls, Mid, End and Eave

## APPENDIX

X-2	Installation of Adapter Walls (to other units)
X-3	40' and 50' Gabled Ends, End Center Bars and Unique Lacing for Gabled End
X-4	Installation Time chart -- Estimates Time and Crew Requirements
X-5	Guidelines for Disassembly
X-6	Weights, Measures and Suggestions for Packing and Storing
X-7	Template Drawings for Baseplates and End Upright Anchor Plates
X-8	Base Loads for Temporary Structures -- Wind Reactions at Baseplates
X-9	Rafter Chart for 30', 40', 50' & 60' AnchorSpan™
X-10	Installation Sequence at a Glance
X-11	NOTES
X-12	Limited Warranty/Maintenance Tips
Back Cover	Cautions and Liability Limits

# AA ANCHORSPAN™ FRAME/HARDWARE PARTS LIST

(See pages 3 & 4 for illustrations.)

Part/Assembly Description	Quantity	Comments
AA Base Column Assembly		2 per beam
AA Apex Assembly		1 per beam
AA 40' Rafter Assembly		2 per 40' and 2 per 60' beam
AA 50' Rafter Assembly		2 per 50' and 2 per 60' beam
AA 60' Rafter Assembly		2 per beam (each = a 40' and a 50' joined)
AA End Upright (Short)		1 per 30', 2 per 40, 50' and 60' ends
AA End Upright (Long)		1 per 60' end
AA End Center Bar/40'		1 per 40' Gabled End
AA Center Bar/50'		1 per 50' Gabled End
SpanLatch Purlin		4 per bay, except 30' = 2 per bay
DbL- SpanLatch Purlins		4 per building (if more than 3 beams)
AA Mid Eave Bars 15'		normally 2 per bay
AA End Eave Bars 20'		1/end on 40' & 50', 2/end on 60'
AA Wing Eave Bar 10' (Left)		1/end on 40' & 60'
AA Wing Eave Bar 10' (Right)		1/end on 40' & 60'
AA Wing Eave Bar 15' (Left)		1/end on 30' & 50'
AA Wing Eave Bar 15' (Right)		1/end on 30' & 50'
AA Midwall Ground Bar 15'		normally 2 per bay
AA Endwall Ground Bar 20'		1/end on 40' & 50', 2/end on 60'
AA Wingwall Ground Bar 10'		2/end on 40' & 60'
AA Wingwall Ground Bar 15'		2/end on 30' & 50'
AA Baseplate		2 per beam
AA Baseplate Adapter Bar		2 per end plus 2 per recessed end
AA Purlin Bolt Assemblies		4/(40,50,60) bays, 2/30' bay + 2 per DbL G/End
AA End Beam Bolt Assemblies		12/(40,50,60) building 10/30' building
AA Upright Bracket Bolt Assembly		1 per end upright (see "B" on chart)
AA Wing Eave Brackets		1/wing eave bar (see Chart "x"s with squares)
AA Beam Joint Caps		2/30', 4/40' & 50' or 6/60' beam
AA Bent Arm Pin, 1/2" x 7-5/8"		1 per baseplate + 1 per adapter bar
#10 Hairpin Cotter		2 per bent arm pin
Ratchet Assembly (with hook)		4/bay + 2 per end panel (sloped or gabled)
AA Cross-Cable/ Red-Green		4/15' x-cabled bay (all AA AnchorSpans)
AA Cross-Cable/ Red-Red		4/15' x-cabled bay (all AA AnchorSpans)
AA Cross-Cable/ Red-Blue		4/15' x-cabled bay (60' AA AnchorSpans only)
AA Cross-Cable/ Red-Yellow		4/15' x-cabled bay (50' AA AnchorSpans only)
AA Cross-Cable/ Red-Black		4/15' x-cabled bay (40' AA AnchorSpans only)
Stake Bar, 2' (3-holed)		2 per sloped end panel
Century Winch Assembly		2 per sloped end panel
24" x 5/8" Steel Stakes		2 per end upright (both 60' and adjustable)
42" Double Head Steel Stakes		4 per baseplate + 6 per sloped end
AA AnchorSpan Installation Kit		Kit of Assembly Tools unique to Anchor
Optional Tools/ Accessories		Not in kit (Priced and Sold Separately)
Century Winch Bar Tool		For tensioning sloped end panels
Socket Wrench, 1/2"		Hand tool for beam assembly
Sockets, 1-1/8"		Hand tool for beam assembly
Combination Wrench, 1-1/8"		Hand tool for beam assembly
Tape Line, 100'		For laying out footprint pattern
Drop Cloth 15' x 15'		For protecting fabric during installation
Wood Blocks		Allows finger holds for assembling beams
Stake Puller (Anchor Yanker)		For removing anchoring stakes
Beam Clamp		For hanging weights from beams

Shaded Areas Indicate Items Packed Together

# AA

## ANCHORSPAN™ TERMINOLOGY

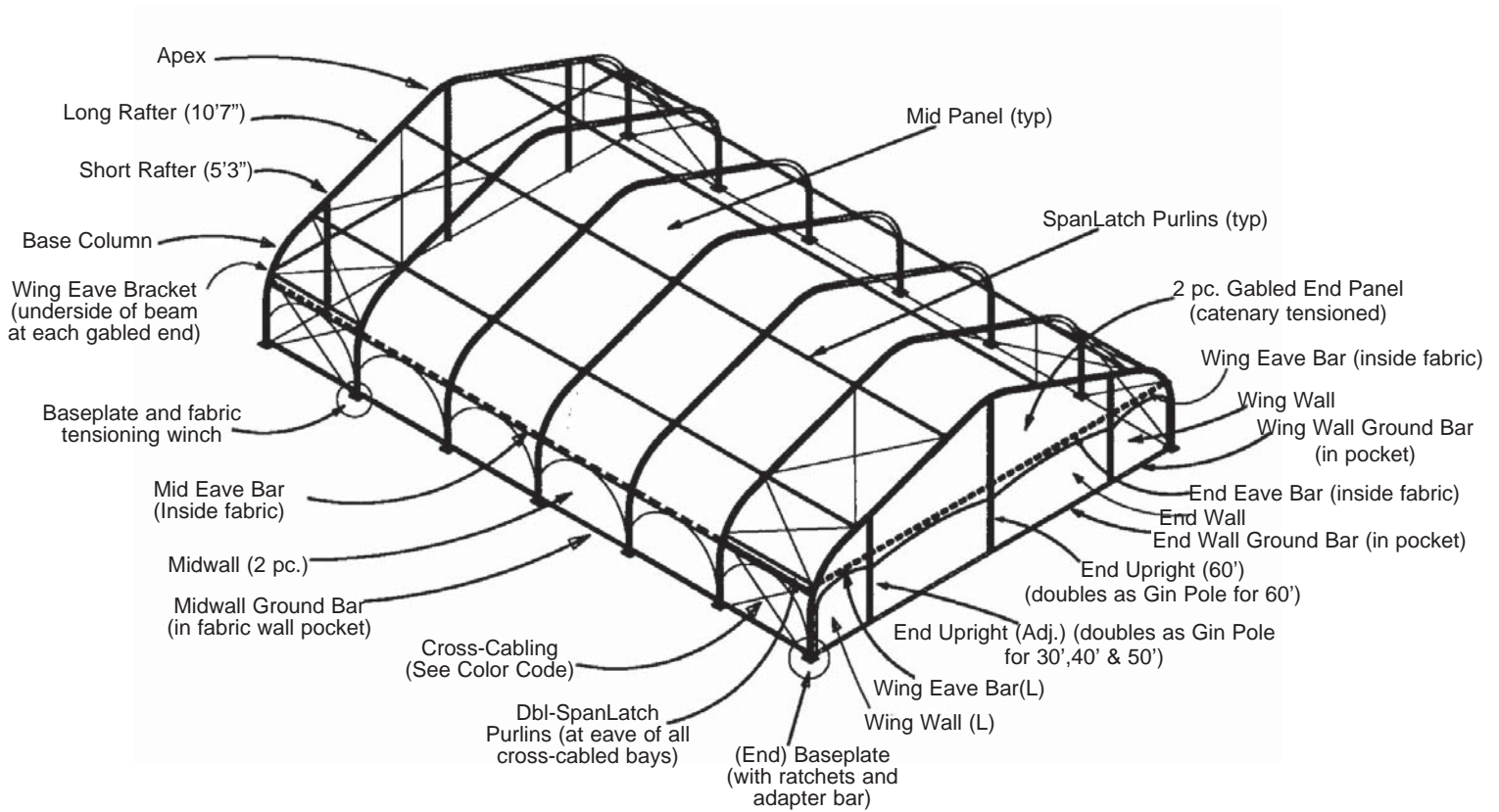

### ACCESSORIES

- |                       |                       |
|-----------------------|-----------------------|
| Purlin Hook (Long)    | Purlin Hook (Short)   |
| Diagonal Beam Brace   | Gin Pole Eye Fittings |
| Beam Hook & Harness   | Eave Bar Cradle       |
| Fabric Hook & Harness |                       |

### CROSS-CABLE COLOR CODE

- |            |                               |
|------------|-------------------------------|
| Red/Green  | Lower Cable -- All Spans, AA  |
| Red/Red    | Middle Cable -- All Spans, AA |
| Red/Blue   | Upper Cable -- 60' Spans, AA  |
| Red/Yellow | Upper Cable -- 50' Spans, AA  |
| Red/Black  | Upper Cable -- 40' Spans, AA  |

# AA ANCHORSPAN™ COMPONENT ILLUSTRATIONS

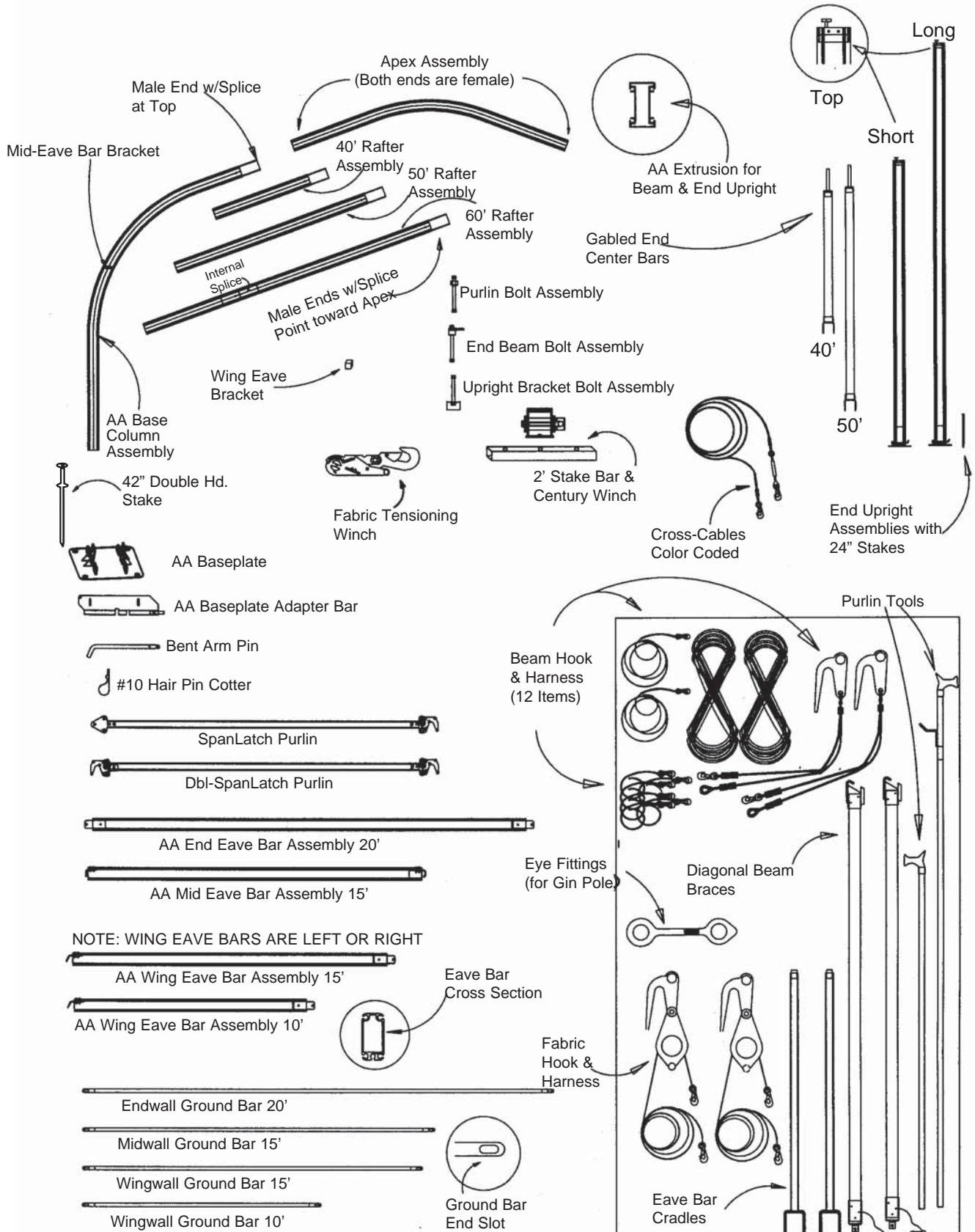

ANCHORSPAN INSTALLATION KIT

# INTRODUCTION

We thank you for purchasing the AnchorSpan™ clearspan fabric structure from Anchor Industries Inc. The AnchorSpan™ is designed to provide a balance between ease of installation and the aesthetic appeal of the curved beam structural configuration.

This assembly manual is for all **AA AnchorSpans™, including 30', 40', 50' and 60' wide** units. We recognize that every installation site is unique with its own individual obstacles and requirements. For instance, some sites may have very tight perimeter restrictions such as cyclone fences or existing permanent buildings. Others may involve installing the AnchorSpan™ over a pool or mounting it on an elevated stage. Though we cannot give detailed descriptions of every technique that may be needed for all possible unique situations, we will be happy to share whatever insights we have from prior experience. Just call **1-800-544-4445** and talk with our customer service representatives.

Some of the unique situations mentioned above may require specialized rigging or the use of motorized equipment to lift or position beam components; however, for most typical situations, **the AA AnchorSpan has been designed for simple, manual installation.** In this manual, we have described a manual installation using simple, common hand tools and a few unique assembly tools available from Anchor. This technique uses a gabled end upright frame member as the gin pole for erecting the beams and (2) readily available 12' step ladders as the only aerial equipment. The real heart of the AnchorSpan™ unit is the **SpanLatch™** purlin system that allows a positive lock at each purlin location using hand-held tools from ground level.

## **For Installations required to meet code certification.**

In this installation manual, we describe a temporary installation using 42" tent stakes for anchoring. NOTICE. These stakes may not be adequate to meet the loading as defined on footing layout drawings provided. Furthermore, if your application of this structure requires meeting any other loading or other code compliance, you should then contact Anchor Industries to confirm whether your unit has been configured to meet those code requirements. Generally, anchoring with standard tent stakes will **not** meet code. Depending upon load ratings, **permanent anchoring will require at least one of the following:**

1. **Multiple Staking** — consult with Anchor Industries regarding baseplate extenders for multiple staking.
2. **Concrete pier-footings** — Anchor supplies base load reactions that will enable your local concrete contractor to design and specify proper footings and anchor bolts.
3. **Earth anchors** — you can obtain Duckbill and Manta Ray earth anchors from **Foresight Products LLC**, phone 1-(800) 325-5360, fax #(303) 287-3866. Adapter plates may be necessary to allow the AnchorSpan™ base plates to use these permanent earth anchors.
4. Others as may be defined by your local professional engineer.

NOTICE: It is the owner's responsibility to select the proper anchoring devices required to properly anchor this structure.

# AA ANCHORSPAN™ INSTALLATION SAFETY GUIDELINES

Your own installation techniques will evolve to fit the varied needs of your clients, the experience level of your installation crews, the nature of other tentage that may be common to the installation site being planned, and the equipment that you may have previously available or with which you feel most comfortable. Whatever techniques you adapt for your crews, we encourage you to keep safety utmost in mind.

Please read through this assembly manual completely before beginning your installation. Be sure the proper equipment, crew and safety precautions are in place. We hope that you enjoy the design features of the AnchorSpan™ each time the unit is installed.

1. It is recommended that workers wear safety shoes and hard-hats on site.
2. When moving beam sections by hand, use proper lifting techniques to protect the back, and avoid pinching fingers while making hardware connections.
3. Never permit workers to stand or walk even briefly in the falling path of a beam as it is being raised or lowered.
4. Be aware to avoid contact of beams with any overhead power lines near the site.
5. When anchoring the structure, avoid all underground power lines and gas lines or other utility easements.
6. Keep site clear of debris to avoid tripping, especially while carrying components or bundles of fabric.
7. Do not drag bundles of fabric on concrete, asphalt, or ground as this can cause damage to the fabric from abrasion through the bag.
8. If a worker climbs onto the fabric “roof” of the structure, a lifeline should be attached to the beam system itself as a backup safety precaution against possible flaws or prior damage that might have weakened the fabric.
9. To avoid damage to purlins, control them manually during installation. Do not let them swing against the beam stop under their own momentum. When pivoting beams to vertical, or when lowering, use a smooth motion and avoid jerks that could snap or bend purlins.
10. When using manual rigging to pivot beams to vertical, first clear the area of items that could cause tripping or slipping as workers back up to pull the beam.
11. When erecting beams, stabilize the first beam with diagonal beam braces. As 2nd beam is raised, be sure to align the beam system vertically and stabilize with cross-cabbling before proceeding. (Note: if cabling is being installed in second bay instead of first, be sure to check and correct vertical alignment frequently until the structure is stabilized by at least one bay of cross-cabbling. Beams that are leaning are dangerous and should be corrected before proceeding.
12. The installation method described here requires coordination of tasks between workers. A safe installation is dependent on that coordination.

# EQUIPMENT AND LABOR RECOMMENDATIONS FOR MANUAL INSTALLATION

Labor: (See Appendix, page X-4)

AnchorSpan™ from 30' wide to 60' wide can be manually installed safely and efficiently by a crew of (6) laborers using the tools recommended below. With careful planning, depending on personnel and equipment, smaller crews can be used, especially on the narrower spans, but we suggest starting with (6) workers and reducing crew size only as your own experience indicates that this reduction will in no way compromise safety. It is recommended that job site crew always wear steel-toed shoes and hard-hats.

Tools and Equipment (Unique to Anchor Industries Inc): (See sketches on Page 4)

AnchorSpan™ Installation Kit:

- (1) Long Purlin Hook
- (1) Short Purlin Hook
- (1) Gin Pole Double Eye Fitting
- (1) Beam Hook and Harness
- (2) Fabric Hook and Harness
- (2) Diagonal Beam Braces
- (2) Eave Bar Cradles

Additional Tools (Available from Anchor) This list of tools is also suggested for the installation of the AnchorSpan™. They are available from Anchor Industries or from your local hardware or lumber stores. For Anchor prices, see the Installation ,Labor, Tools, and Equipment page in the AnchorSpan™ quotation form, or call 1-800-544-4445 for quick pricing by phone.

- |                                 |                              |
|---------------------------------|------------------------------|
| Socket Wrench (1/2") (2)        | Tape Lines (100') (2)        |
| Sockets (1-1/8") (2)            | Drop Cloths 15'x15' (2)      |
| Combination Wrench (1-1/8") (2) | Wood Blocks (2"x4"x3')       |
| Stake Puller (1)                | (suggest 10 blocks per beam) |

Tools not available from Anchor: The following tools, or their equivalent, are needed for safe manual installation of the AnchorSpan™. You may already have them in inventory. If not, they are readily available commercially.

- (1) Stake Driver (optional)
- (2) Sledge Hammers (10 lbs, or heavier)
- (1) or (2) Step Ladders Minimum 12' Tall (preferably 14' or taller if available, see below).
- (To fully Complete the End Panel Lace Line, use 14' Ladder or Taller - See Page 18, section 5)

Note: For permanent installations, earth anchors or concrete footings with anchor bolts could be required. Customer should supply permanent anchoring devices, as well as the wrenches and hand or power tools for proper installation of this anchoring system. Unusual site conditions, such as assembly on a stage, on elevated pilings, or over a pool may require additional equipment such as fork-lifts, man lift or cranes.

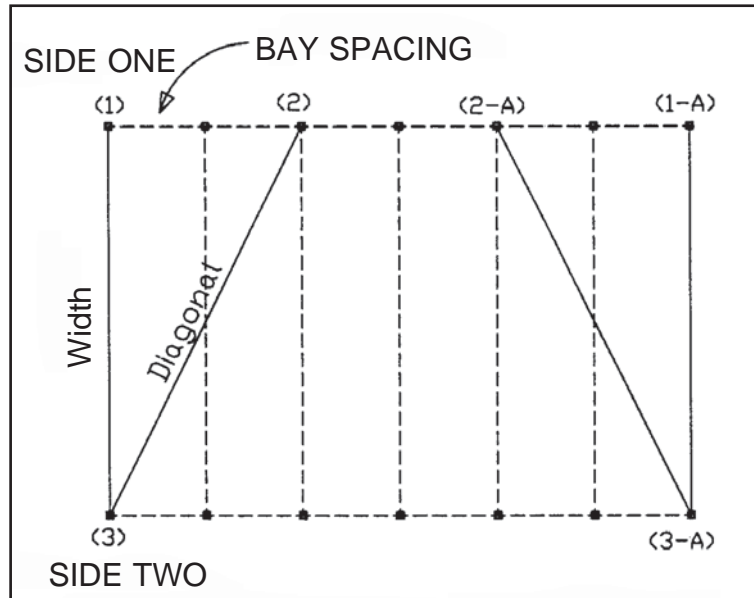

Diagonals to the 3rd Baseplate of Typical Spans

Width	Bay Spacing	Diagonal Measurement
60'	15'	67' 1"
50'	15'	58' 3-11/16"
40'	15'	50' 0"
30'	15'	42' 5-1/8"

Footprint Layout: (Note: For each structure sold, Anchor provides a specific Footprint Drawing showing plate locations, diagonals and loading requirements for proper anchoring.)

- \* Strike a straight line for "side 1" of the structure according to desired site orientation.
- \* Mark 15' increments along this line and position baseplates (See Footprint Drawing).
- \* Find an opposite corner by holding the end of one tape at point "1" and another tape at point "2" and pull straight until the appropriate "width" and "diagonal" measurements for the span you are installing (see above chart) intersect on the two tapes at point "3".
- \* Reverse this procedure to locate the remaining corner on the opposite side of the structure using points "1-A", "2-A", and "3-A"
- \* Strike a straight line between points "3" and "3-A" representing "side 2"
- \* Position baseplates in 15' increments along this side and be sure that opposing baseplates on opposite sides of the structure are squared toward each other (See Footprint Drawing).
- \* Drive (2) stakes in diagonal corners of each baseplate. The remaining (2) stakes can be driven into undisturbed soil after the beams have been erected.

# AA ANCHORSPAN™ HARDWARE PATTERN

For Gabled End Configuration for Beam Assembly (on the ground)

ORDER INCLUDED

1 2 3 4 5 etc. 6 7 8 9

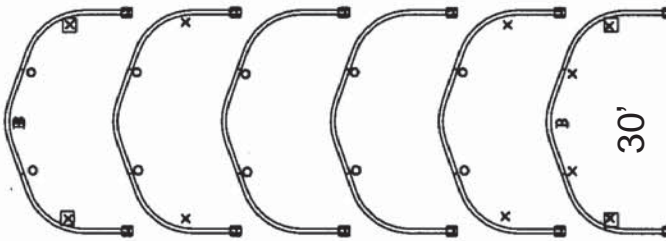
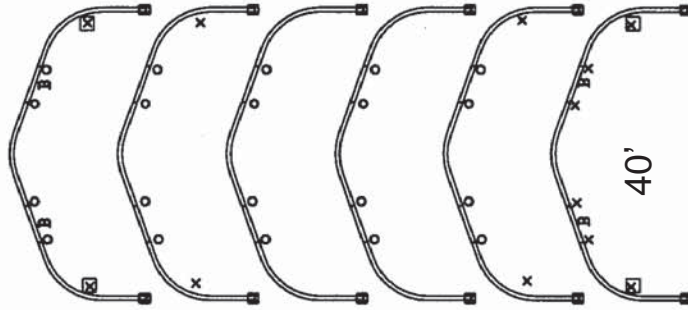
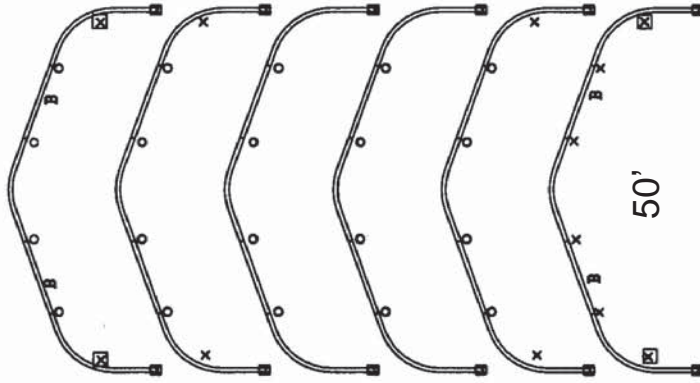
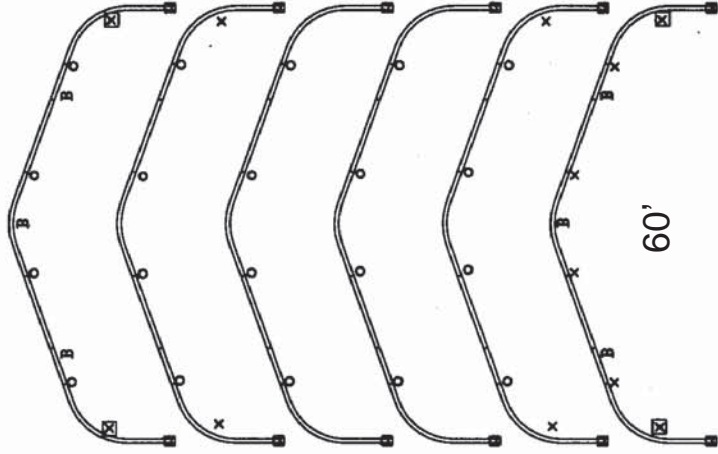

## "O" HARDWARE

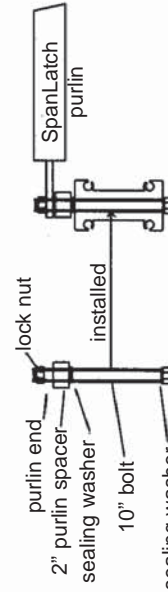

TYPICAL PURLIN BOLT ASSEMBLY

## "X" HARDWARE

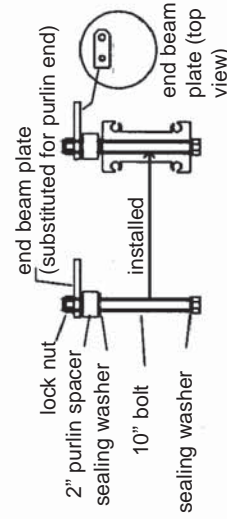

TYPICAL END BEAM BOLT ASSEMBLY  
Note: X indicates location of wing eave brackets (added at head of end beam bolt assembly.)

## "B" HARDWARE

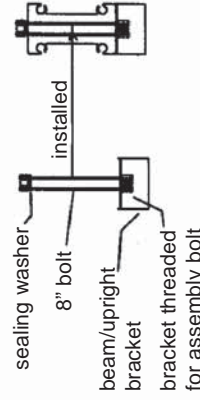

TYPICAL UPRIGHT BRACKET ASSEMBLY

When Structure is disassembled, hardware should be stored as assembled above.

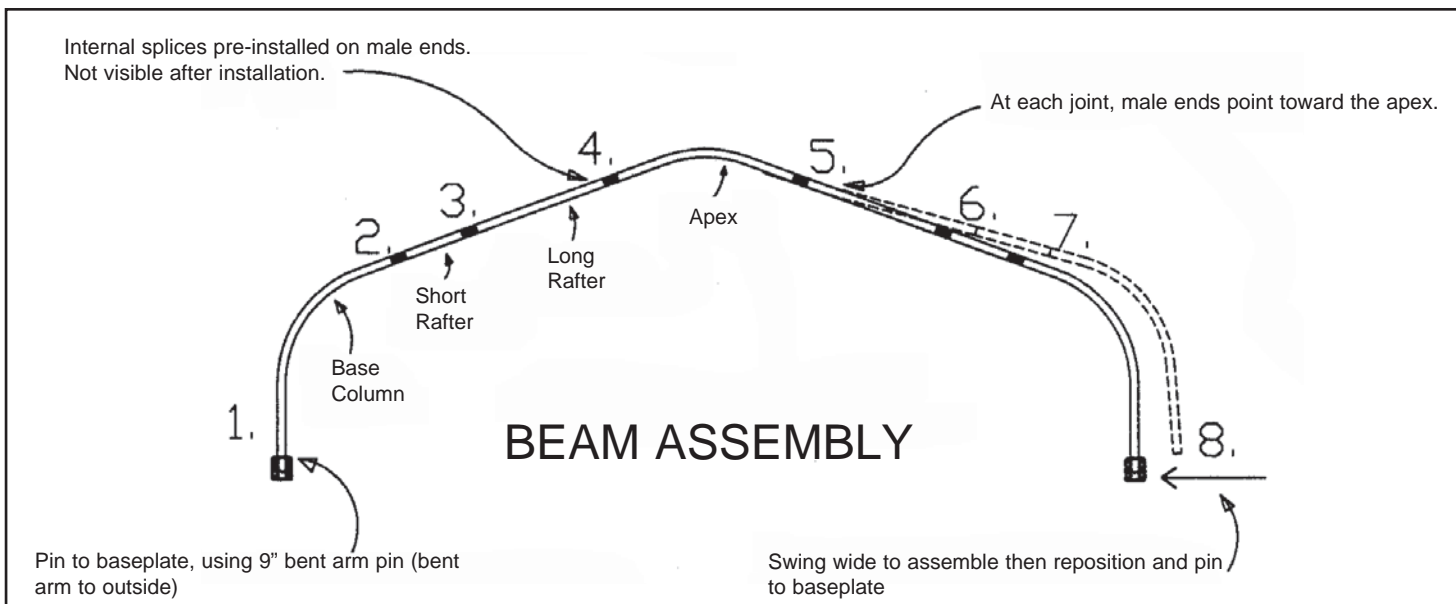

### Beam Assembly:

Note: Beams are shipped from the factory with splices pre-installed in base columns and rafters. It is intended that the horizontal bolts securing the splices be left in place. The ends with the splice are the male ends, and in all “AA” spans the male ends point toward the apex of the structure. Consult the Hardware Pattern on the previous (facing) page for correct hardware configuration. Bolt Assembly “O” is used on all overhead joint locations except on the first beam to be raised. Bolt Assembly “X” is used on overhead joint locations on the end beam that will be raised first and at the eave purlin locations of cross-cabled bays. These take the place of the fixed end of the SpanLatch™ purlin to secure purlins at locations where they do not overlap.

At the eaves of any beam that will support a gabled end frame, add a wing eave bracket at the bolt head at the underside of the beam (see locations on hardware chart where the “X” is enclosed within a square).

Bolt Assembly “B” is used only to hold end uprights (at the non-joint locations) of any beam that will be equipped with a gabled end frame. At those locations, pop out the hole plug installed at the factory and insert the Upright Bracket bolt assembly.

Briefly, the 40’, 50’ and 60’ spans with (2) cross-cabled bays will use (12) “X” Bolt Assemblies, and all other joint bolt locations will be “O” Bolt Assemblies. The 30’ span has only (10) “X” Bolt Assemblies.

The rafter pattern shown above is for the 60’ span. ( See appendix page X-9 for correct rafter pattern for 30’, 40’, and 50’, spans.) Begin assembling the first beam by pinning the female end of one base column to a baseplate and proceeding toward the opposite side according to the numbered order shown. The angled end of the baseplate pin goes to the outside of the structure. In assembling a beam, do not start at both sides and work toward the middle.

The purlin bolt is installed with the head to the bottom (or inside) of the beam and the threads to the upper (or outside). Be sure the purlin bolt at each joint has been installed before proceeding to the next joint. At this time, leave the nut loose at the end of the bolt (for later purlin installation). Continue installing female to male ends at each joint until the opposite side baseplate is reached. Swing the beam wide of its baseplate (as shown) while the final base column/rafter joint is being assembled. Then swing the beam back into place and pin the female end of the final base column into its baseplate. Continue assembling beams until all are finished flat on the ground.

## BEAM ASSEMBLY COMPLETE

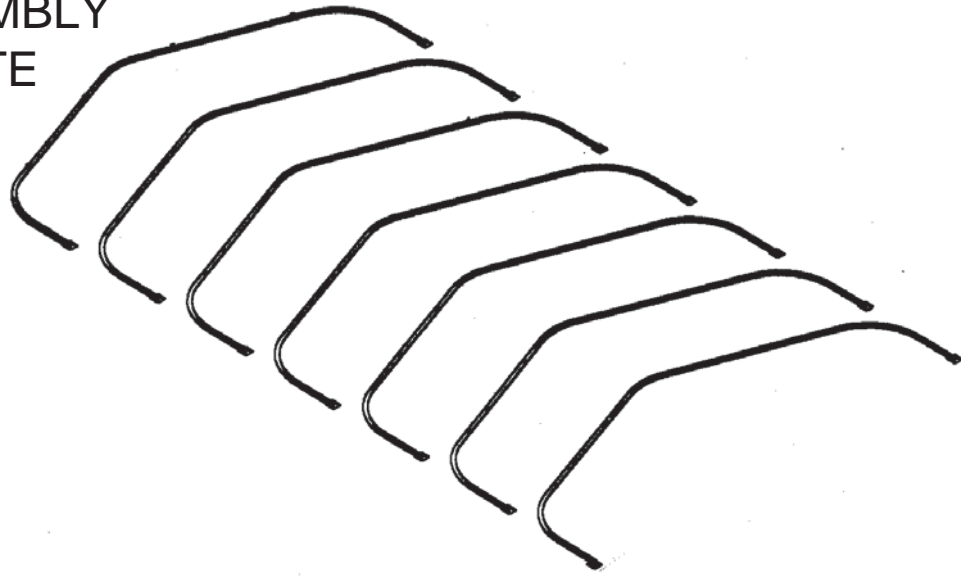

Continue assembling beams until all are completed flat on the ground, as above.

### Install SpanLatch Purlins and Cross-Cabing

On all but the first end beam to be raised, bolt the fixed ends of SpanLatch purlins to the top of the 2" cylindrical purlin spacer at each apex joint and each base column joint (#2, 4, 5, and 7 in drawing on Page 10). Snug-tighten the locking nut of each purlin bolt and gently swing each purlin outward & downward until it rests with its stop nut against the beam (jaws open downward). (To avoid damage, do not let purlins swing under their own momentum.) In cross-cabled bays, attach the snap end of each color-coded cable to the appropriate purlin end and let the turnbuckle end of the cable hang to the ground. (See the Terminology drawing on Page 3 for the color code of each cable location. See Page 9 for correct bolt assemblies.)

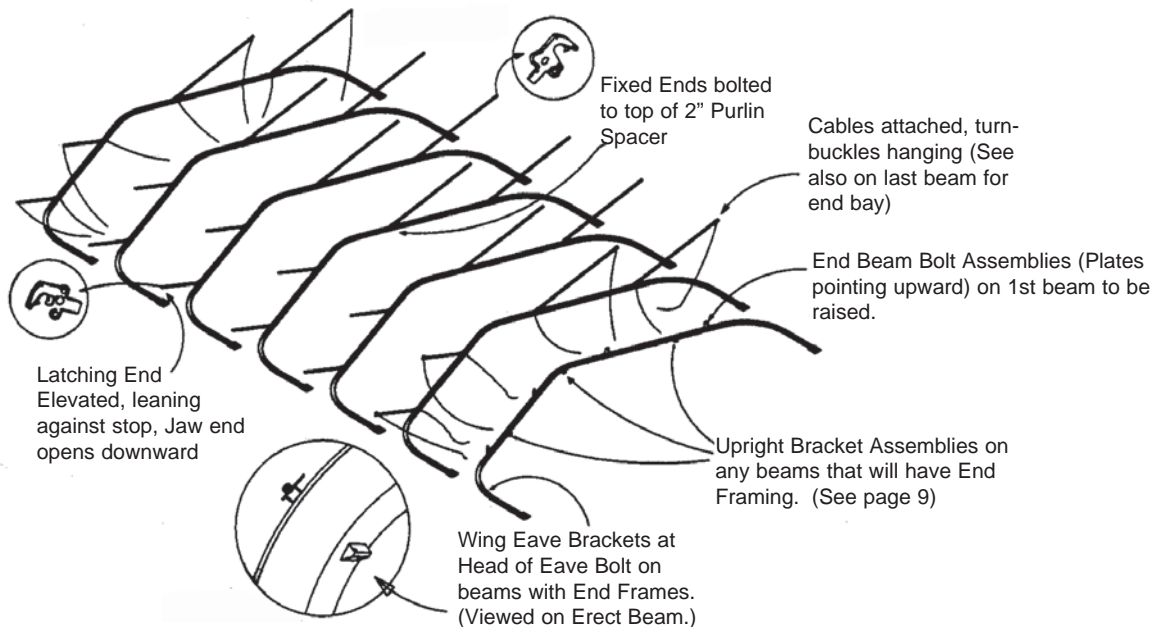

Before raising first beam, Upper ends of cables are snapped to purlins. Upright brackets and wing eave brackets are installed where needed for Gabled End Frames. (see Hardware Chart on Page 9)

(Before Erecting beams, see optional ground installation of the Gabled End Panel on Page 18. In other than windy conditions, this can allow the ground-lacing of gabled end panels and ease the later installation of end uprights, as well.)

Erect Beams using the Gin Pole Method (See figure below)

Attach an eyebolt/eye nut fitting (see installation kit on Page 4) to the top of the end upright to be used as a gin pole (the 60' End upright for 60'spans or the adjustable upright for 30', 40', and 50' spans.) Position the gin pole so that its base is approximately 7' inside an imaginary line joining the 2 baseplates of the beam to be erected. (somewhat less for 50', 40', or 30'spans). Attach the hook of the beam harness to the apex purlin plates (or the end beam bolt assembly) of the first beam to be erected, letting the two cables attached to safety ropes trail backward under the beam. Attach the remaining two beam harness cables to the eye of the gin pole facing the ground (see point "B"). Avoid twisting the cable. to the gin pole eye facing the sky, attach two pull ropes and position two workers on each, preparing to erect the beam. Follow steps below to coordinate worker positions to safely pivot the beam to a vertical.

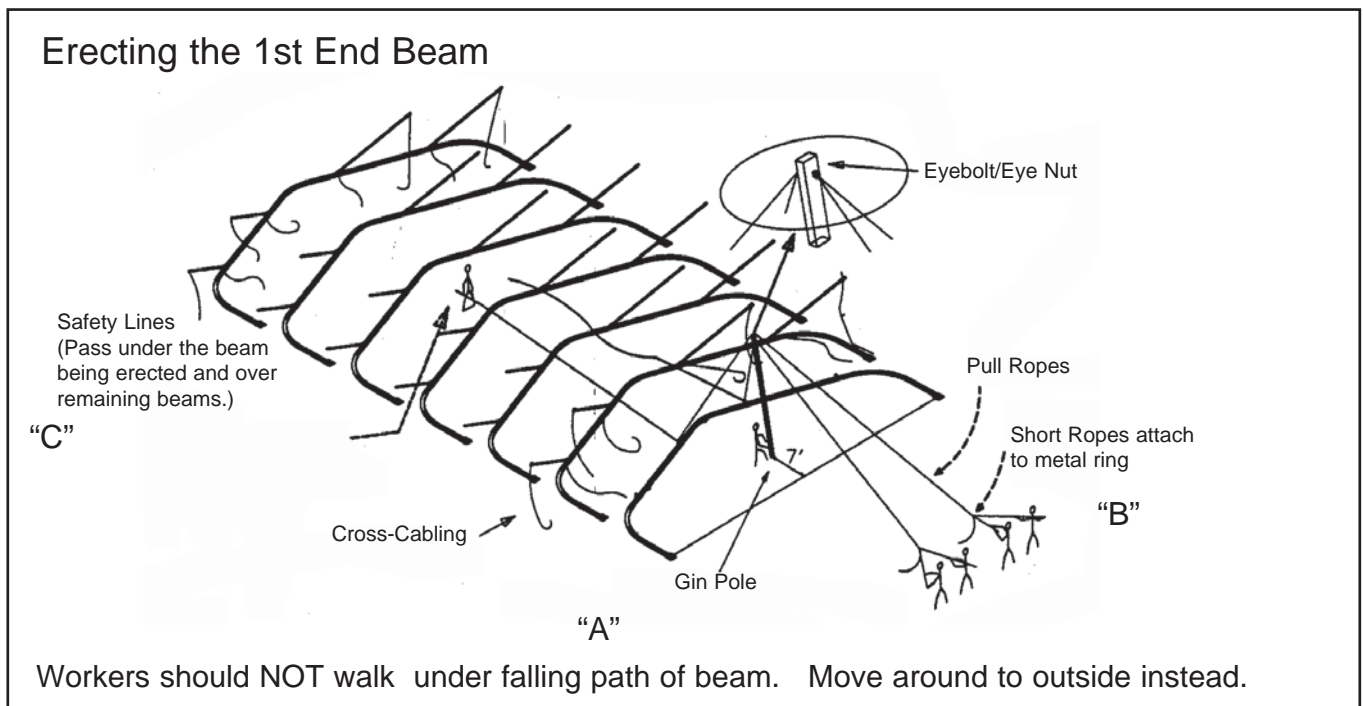

The Gin Pole is a center end upright (for 60' spans) or an adjustable upright for 30,40,&50' spans. Install eyebolt/eye nut fittings (see installation kit on Page 4) to top of upright.

60' Procedure (1st Beam):

- Step #1 (1) Worker stands gin pole, jamming base into ground surface. ("A")
- (5) Workers man pull ropes ("B") and rotate beam to about 60 degrees vertical

- Step #2 (2) Workers leave pull ropes and go to point ("C") to man safety ropes.
- (4) Workers pull beam to about 80 degrees of vertical.

- Step #3 (2) Workers man safety lines preventing beam from moving beyond vertical ("C")
- (3) Workers man pull lines to hold beam near vertical ("B")
- (1) Worker leaves pull lines to install diagonal braces (as shown on next page).

### First beam standing with diagonal brace installed

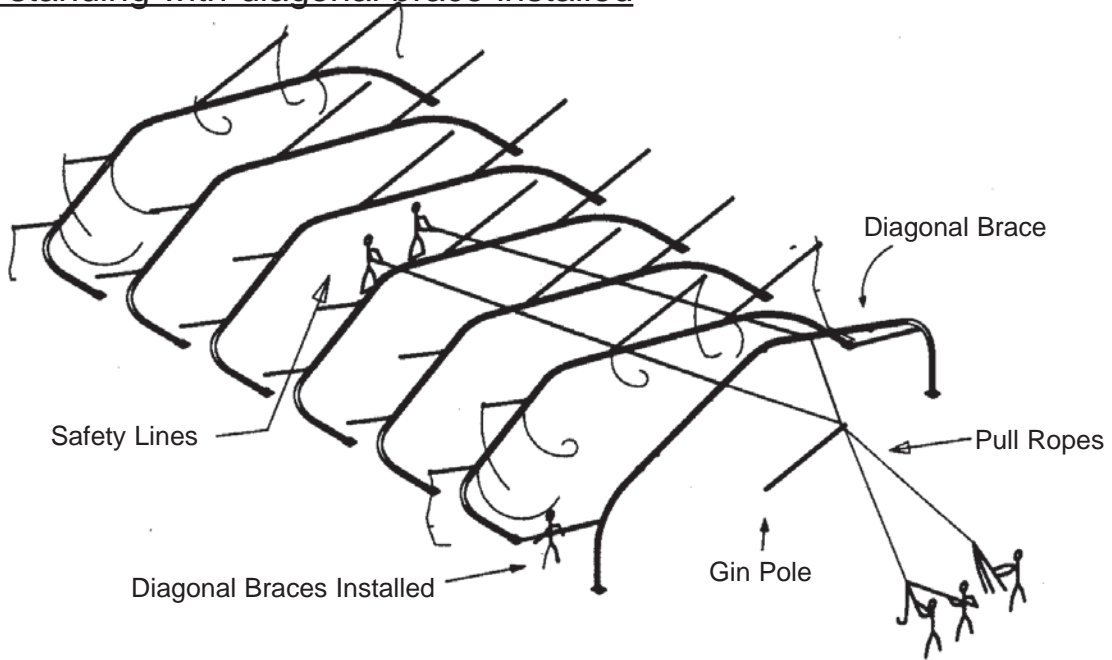

Erecting the 2nd Beam. Erect the 2nd beam the same as above, except that the beam harness hooks to the top hole in the fixed end of the apex purlin. And, instead of diagonal beam braces, the 2nd beam is stabilized by connecting its SpanLatch™ purlins to the first beam (See top of Pg 14). Using the purlin hook, push the SpanLatch™ end of each purlin to the top of the beam a few feet above each joint. Then hook backwards, pulling the latching end down the beam slope to engage the latch. Before erecting remaining beams, proceed to the bottom of page 14 and install the double-latch eave purlins in the first bay, align the first (2) beams perpendicular to the anchoring surface, and connect the lower ends of all cross-cablings in the first bay. When the first bay is stabilized with cabling (bottom, page 14), erect all remaining beams, repeating the cabling pattern in the last and final bay (or a preferred alternate bay).

### Pivoting remaining beams to vertical

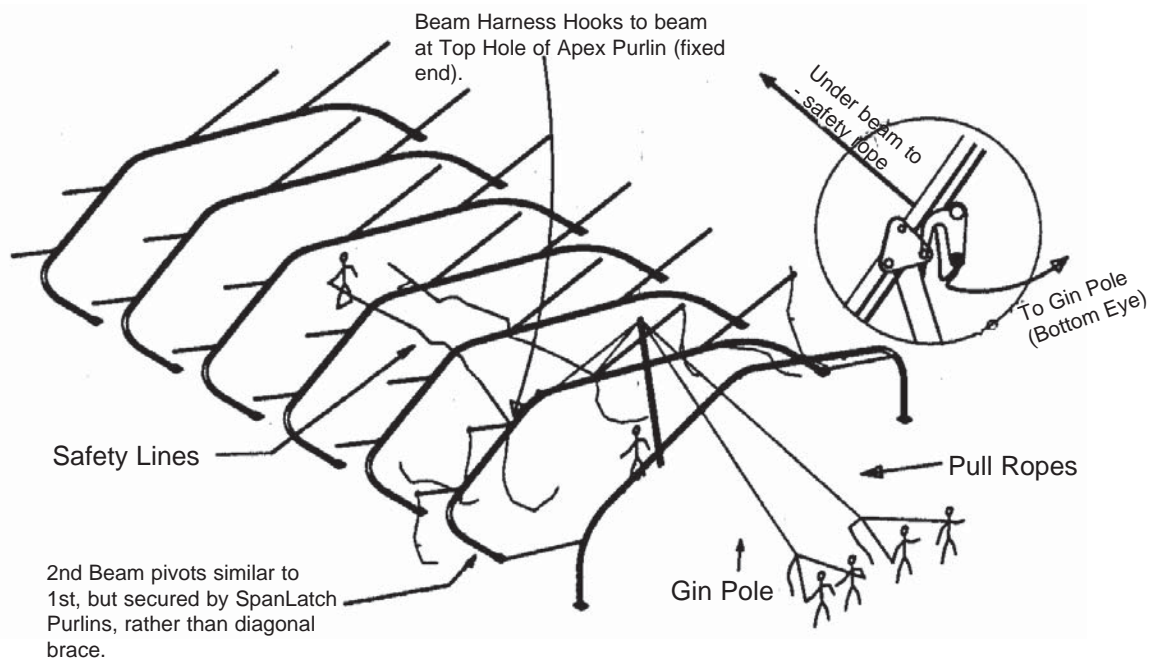

## Engage SpanLatch Purlins between 1st & 2nd beam

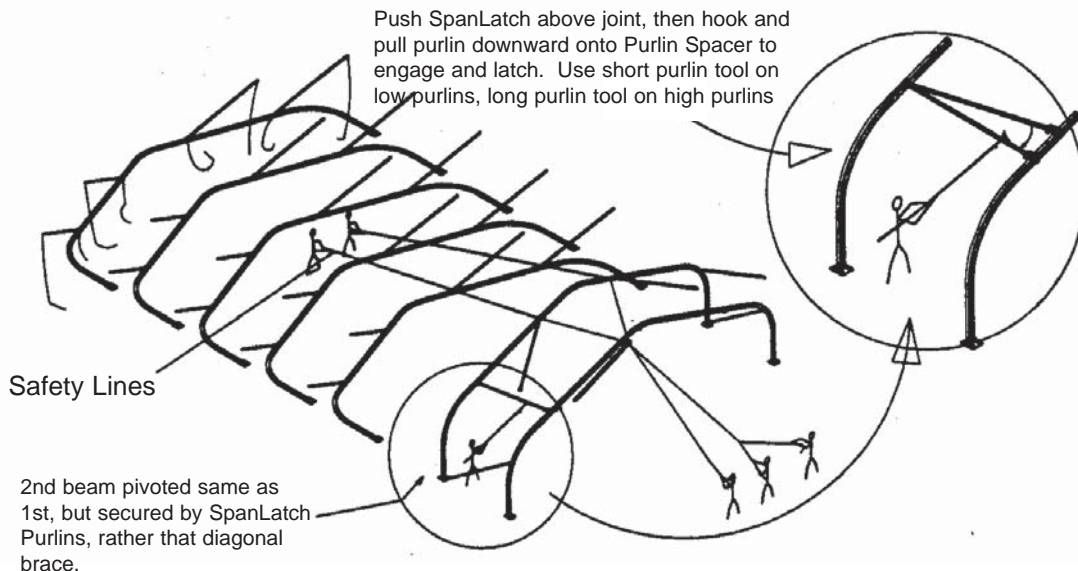

Note: If you intend to use the recessed end configuration, cross-cabing can be installed in the second bay, rather than the first (with ground connections to 3rd beam rather than 2nd).

After all overhead SpanLatch™ purlins have been engaged between the first two beams, install eave purlins and attach the turnbuckle (hanging) ends of all cross-cabing to form the X's shown below (and on page 15) in the end bay of the building. (Note: Eave purlins are double latched purlins, with SpanLatches on both ends.) To install them, simply raise the purlin above the purlin spacer at the eave bolt, with the jaws of the SpanLatch™ purlin facing downward. Then, pull the purlin downward until both SpanLatches engage. (An exception to this procedure occurs in structures with only 3 beams total. In 3-beamed structures, eave purlins will be standard SpanLatch™ purlins, with one fixed end and one latching end.) After the structure is vertically aligned and cross-cabled, continue raising beams by the same technique, using the purlin hook poles to secure each new beam to the standing beams, until all beams are erect (see bottom of page 15). The cabling pattern will be repeated (usually in the last and final bay), although it is acceptable for the cabling to be installed in any (2) bays of the structure.

## Stabilize structure with cross-cabing

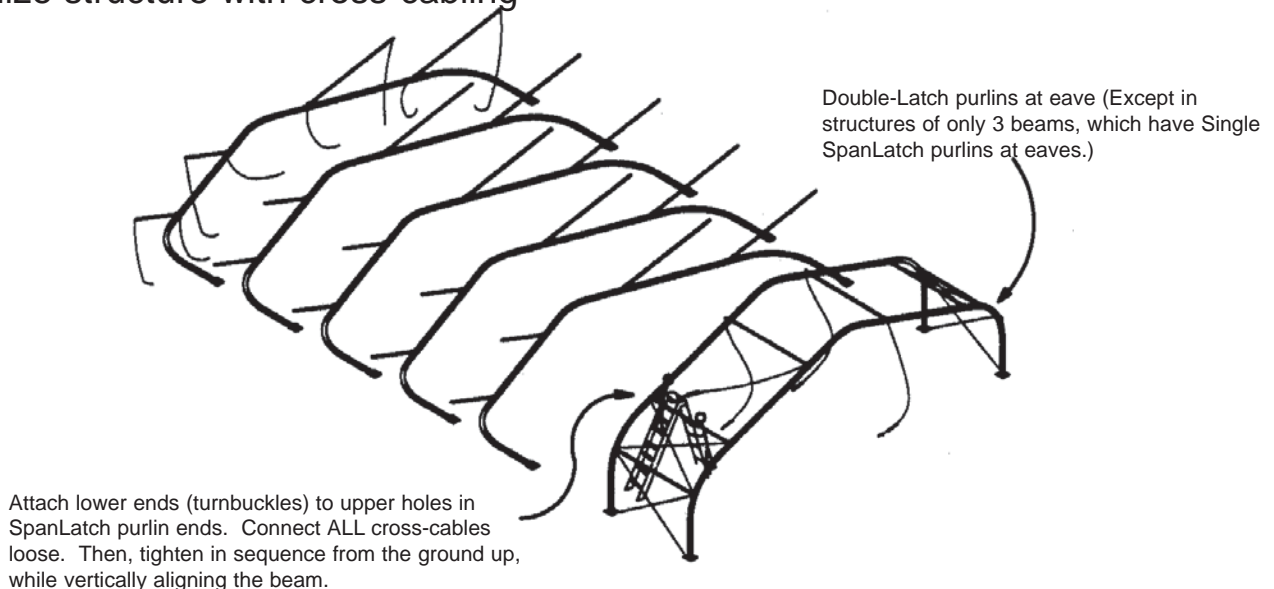

## Beam & Cabling System (Complete)

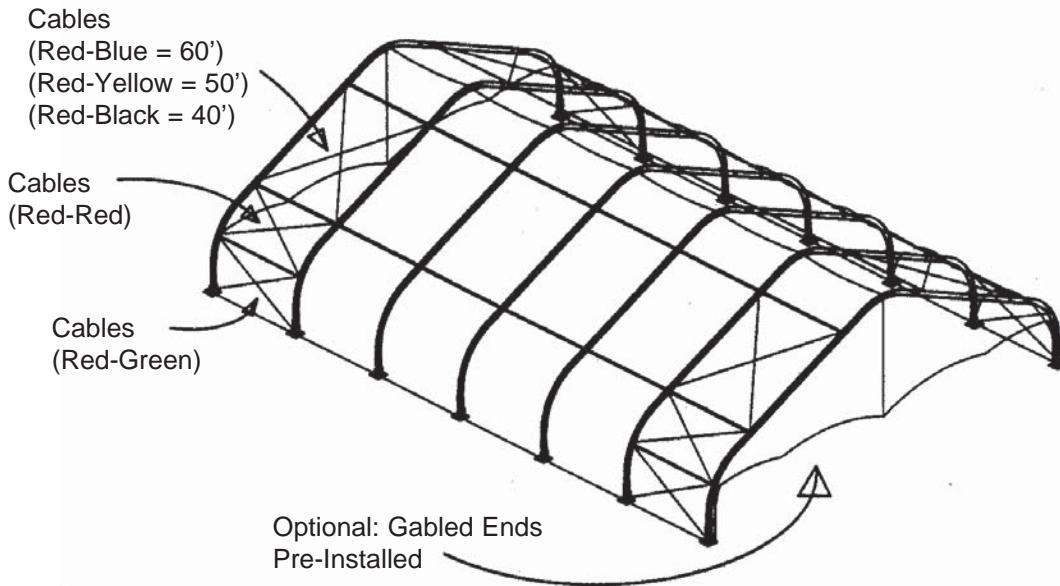

**Fabric Installation (Middle Panels):** (See top of page 16) Before installing fabric, be sure cross-cabling has been installed and tightened to absorb the wind load the fabric will transfer to the beam system. Then proceed as follows:

1. Layout middle panel, as shown, on downwind side of structure. The inside of the panel can be recognized by the raised weave pattern and the inside position of the fabric label.
2. Use the purlin hook pole to install the fabric hook and harness to the apex purlin on the far side of the peak (the side away from the fabric bundle, as shown).
3. Position (2) workers at fabric bundle to guide the fabric kidder into the flares of the outer beam channels (as shown).
4. Position (4) workers on fabric pull ropes. Workers must coordinate pulling so that both sides of the mid panel move together. Pull gently until the panel has rounded the curve of the beam. Then pull more vigorously until the panel has reached the far apex joint where the pulley is located.
5. Use the purlin hook pole to remove the fabric hook from the apex purlin and let it slide down the pull rope into a workers hands. Then continue pulling the panel through the beam, keeping pull ropes in line with the fabric channel as much as possible. The panel will pull easiest if workers stand far out to the side of the structure until the panel begins to round the far curve of the beam. Pullers should then approach the beam and pull from near the base column to complete the installation of the middle panel.

## Installation of Middle Panels

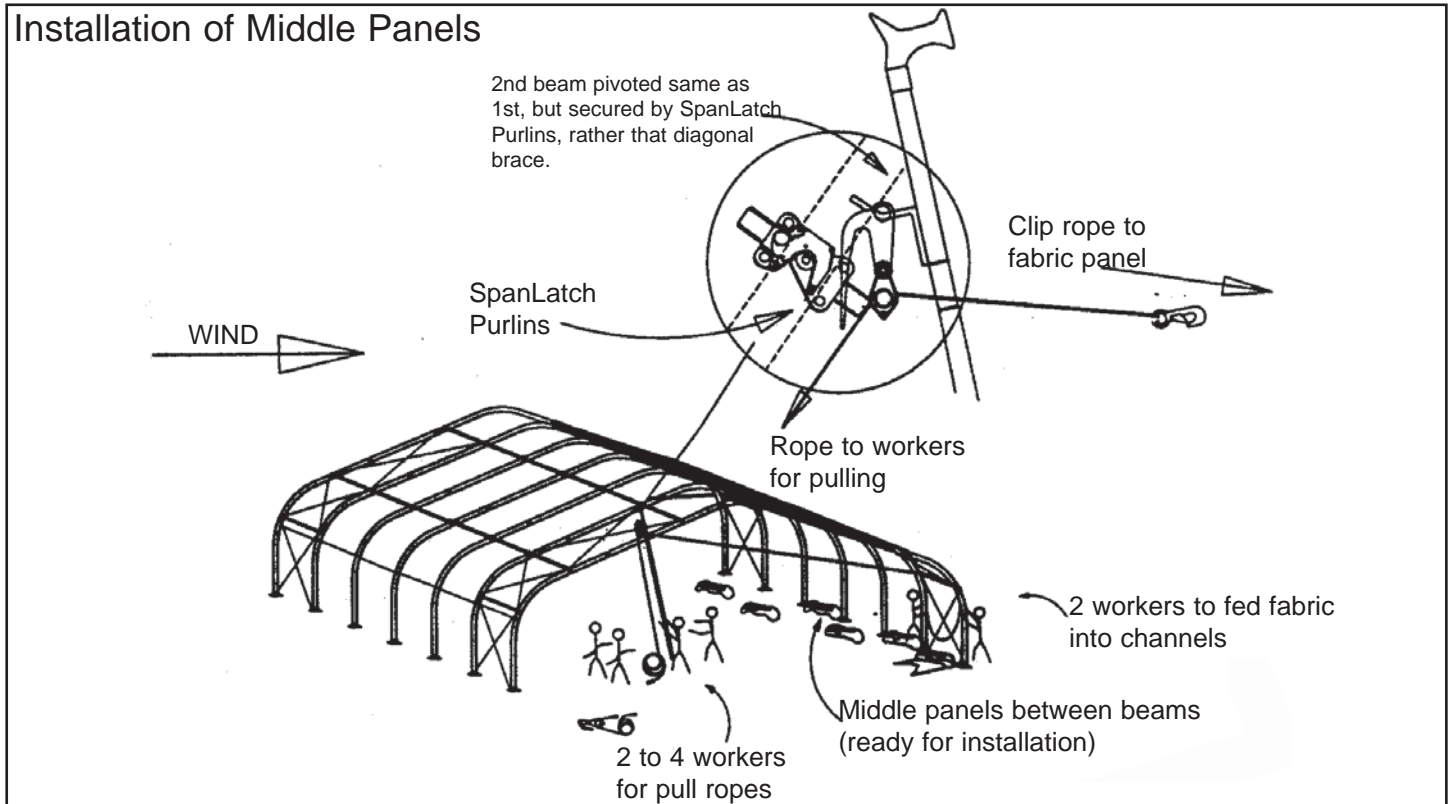

Do not tension the middle panel until the middle eave bars have been installed in its bay and the adjacent middle panel has also been installed. (See Below)

## Installation of Mid Eave Bars

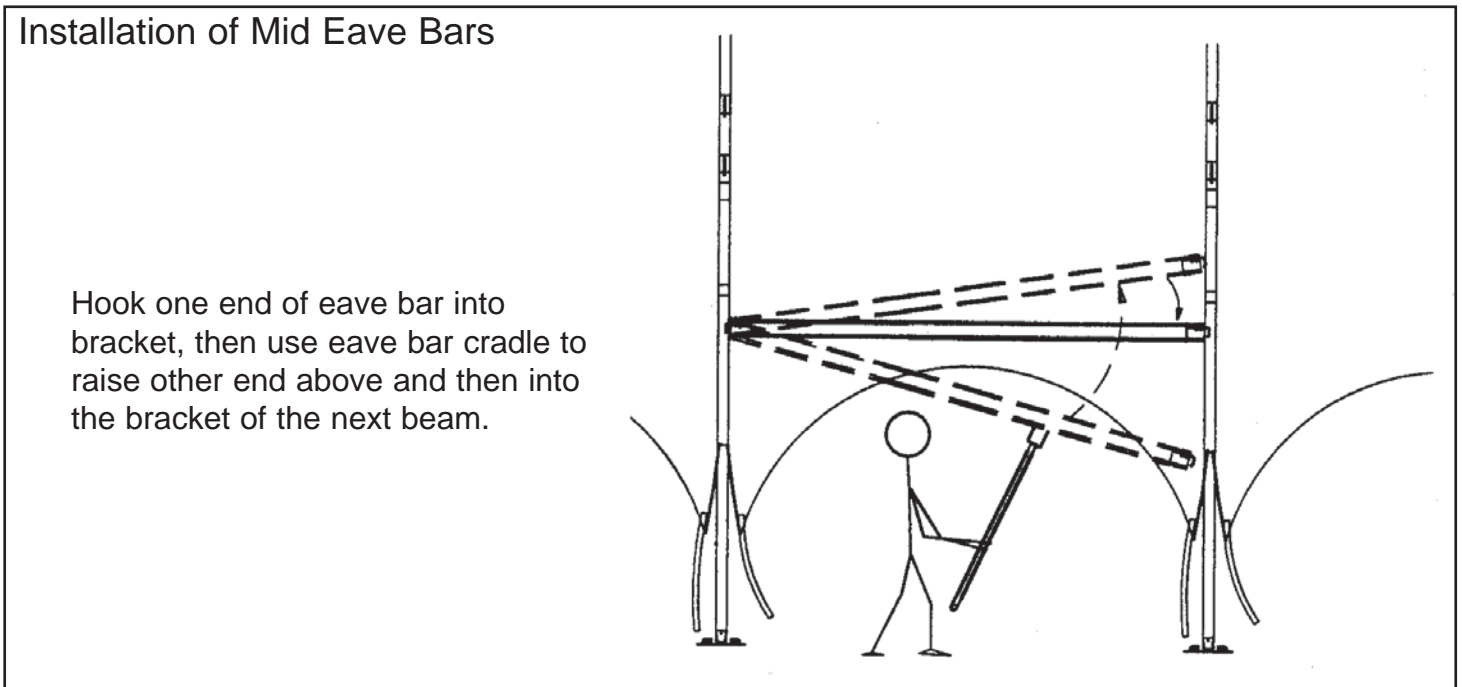

Note: The eave bar will re-form the curve of the middle panel fabric to form a straight line at the eave location. The short eave bar cradles are useful in lowering the eave bar end fittings into their respective brackets, as shown. Tension middle panels after eave bars have been installed.

## Tensioning of Middle Panels

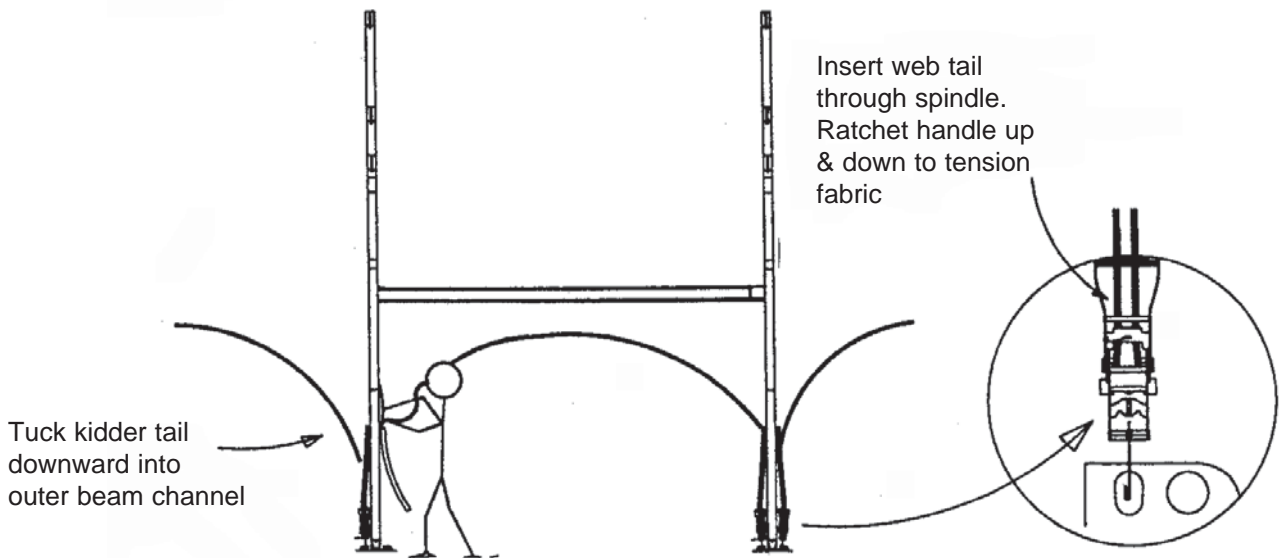

### Tensioning of Middle Panels: (See Above)

1. Tuck the fabric tails of each panel downward into the beam channel flare until all middle panel kidder rests within the outer beam channel.
2. Install (2) fabric tensioning winches with hooks into each baseplate, as shown.
3. Insert the tension webs of each middle panel through the slot in the spindle of each fabric winch and pull all surplus webbing through the winch.
4. Crank the handle of the winch so that the webbing is wrapped around the spindle. Install Gabled End Fabric Panel (See Top of Page 18)
5. Coordinate the tensioning of all four corners of each middle panel, so that tensioning is equalized and wrinkles are avoided. Metal pull rings should be equal distance above the baseplate at all four corners of the panel.

## Install Gabled End Fabric Panel (See top of page 18)

Using a safety line tied off to the frame system, a worker lays on last middle panel and engages caribiner to join the 2 halves of the gabled end and lace down the first 3 or 4 loops.

2 piece end is joined by caribiners at top and bottom of lace line.

Lacing is completed from ladder at ground level. (Minimum 12' ladder see step #5, next page. For full lace, use 14' ladder or taller.)

Feed into Liner Channel

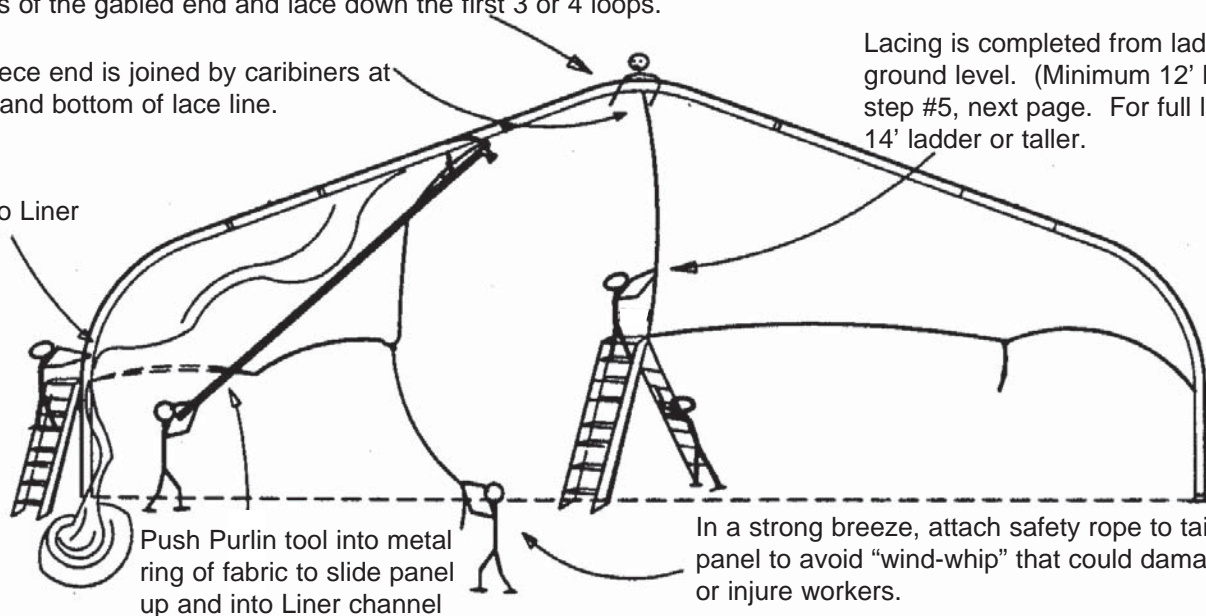

## Installation of 2-pc Gabled End Panel (See bottom of Page 17)

1. Install Gabled End panel into Lower Beam Channel (same as liner channel) on the outer facing surfaces of the first and/or last beam.
2. Because the flared opening in the liner channel is approximately 9 1/2 feet high, a small step ladder will be useful in feeding the gabled end fabric into the beam channel.
3. With workers positioned as shown (page 17) feed half of the 2-pc. end panel from each side of the structure and join the two halves at the top and bottom of the center lace line, using the caribiners provided.
4. Worker at the peak laces down to the 2nd or 3rd grommet and ties the lace at that point. (When standing on fabric at the peak, worker should tie off to the beam system with a safety harness.)
5. Worker on ladder laces from the top of his reach down to the bottom of the lace line. To complete the lace easily, use a step ladder 14' tall, or taller. A 12' step ladder can be used by skipping a few grommets in the area between the reach of the two workers. Close the Velcro weather flap over the lace line, leaving a slight puffy fullness in the flap as a stress release for the Velcro.
6. Tuck the tails of the end panel downward into the channel below the flare. The Gabled End will be tensioned after the end uprights and eave bars have been installed.

### Alternate Method:

2. If weather permits, the gabled end panel can be installed on end beams before the beam has been pivoted to a vertical position. This should only be done when wind does not threaten to de-stabilize the first beam as it stands alone, supported only by diagonal braces. When using this method, it will be necessary to prop up the last beam, as the correct channel lies on it's underside.

Note: Optional Sloped End is installed in the same way except in the Upper Channel. Also, the sloped end is tensioned into century winches anchored with 2-ft stake bars -- See footprint drawing for proper location of winch & stake bars.

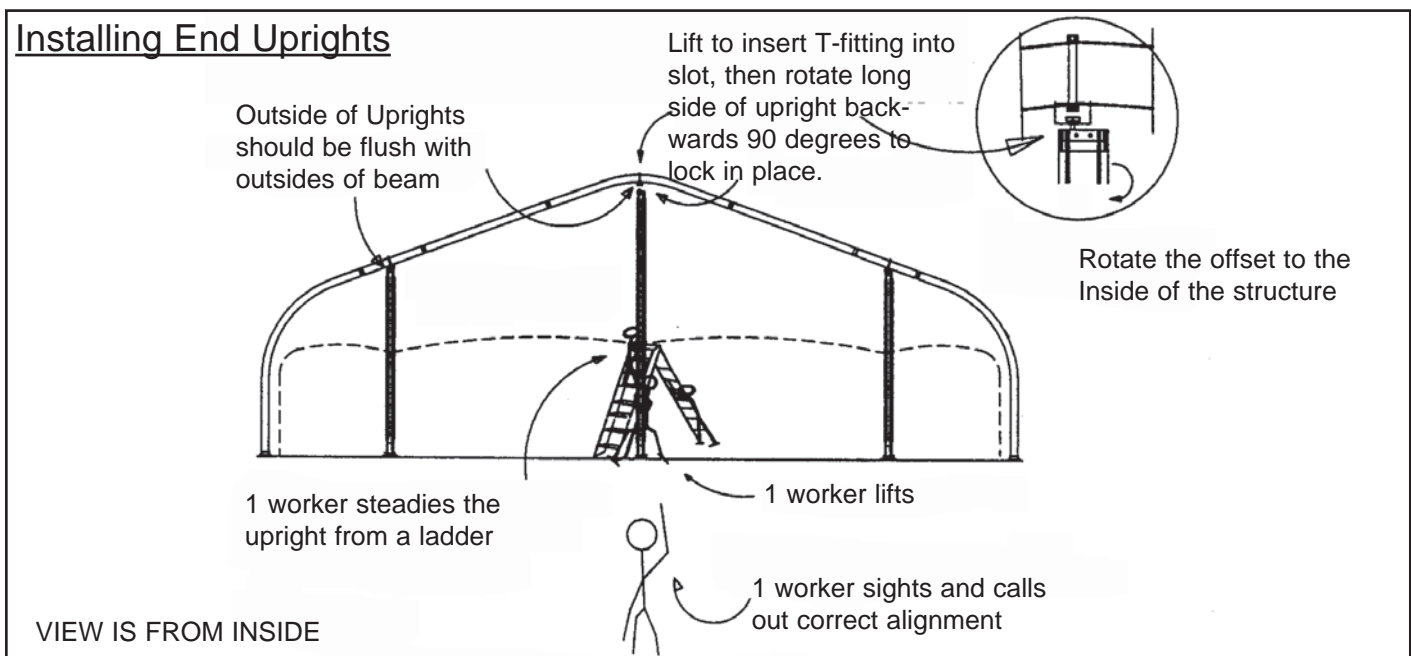

**Install End Uprights:** (See Bottom of Page 18) One worker stands on base of upright at ground level, while second worker walks the top of the upright to vertical. Align the T-fitting at top of upright with the slot of the upright bracket on the underside of the beam. Lift upright until T-fitting enters slot, then rotate upright 90 degrees with offset to the inside (as shown). (Do not anchor the uprights until after the eave bars have been installed.)

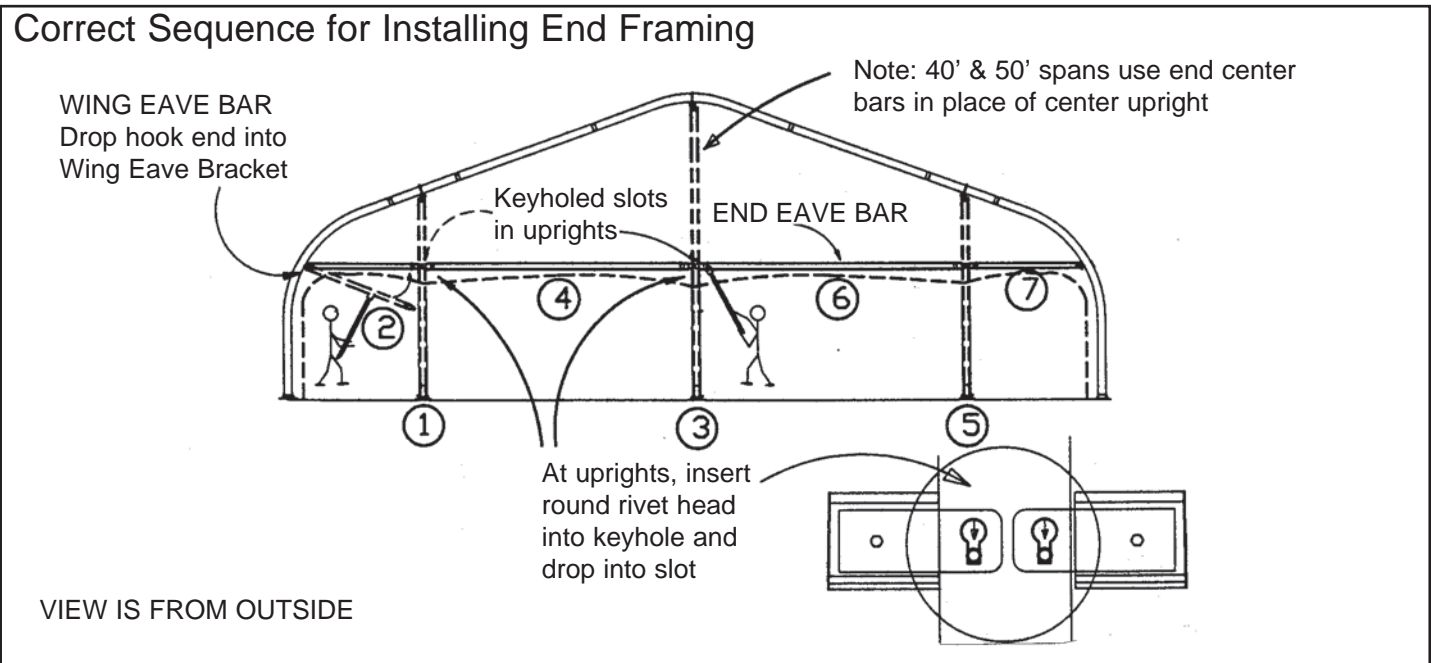

Install end and wing eave bars in the sequence shown above. For later ease of wall installation, be sure the notch (for inserting wall hooks into bottom channel of eave bars) faces toward the inside of the structure. If this is not done, wall can still be installed, but this alignment will make it easier.

Consult the Footprint Drawing supplied with your structure for correct positioning and anchor each upright with (2) 24" stakes (or anchor bolts, depending upon the loading requirements of your installation). (NOTE: On 40' and 50' Spans, see Index Page "X-3" for necessary End Center Bars)

**Install Baseplate Adapter Bars As Shown.** These are required for either Gabled Ends or Sloped Ends.

(If both ends are installed on the same beam, only one set of adapter bars is needed)

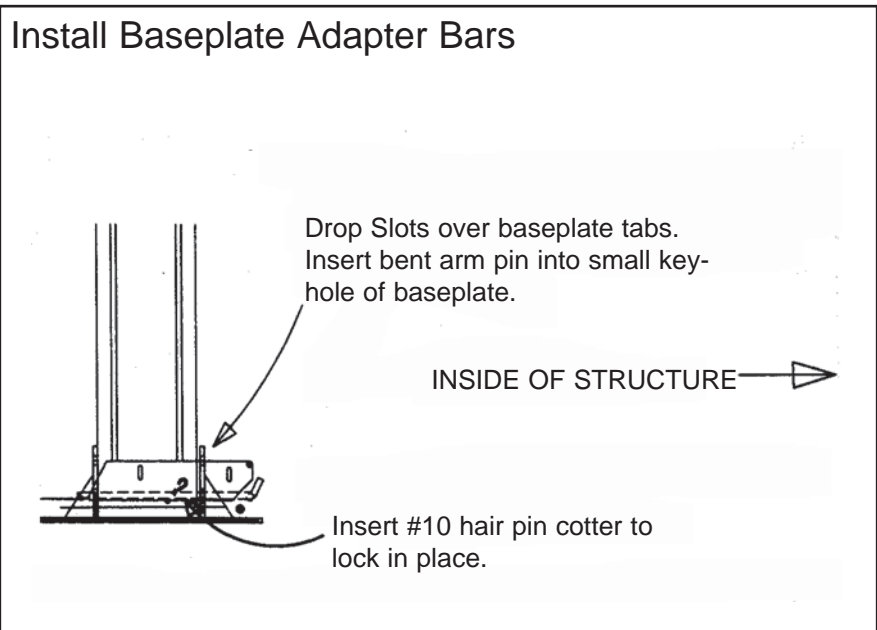

## Tensioning of Gabled End Panel: (See Below)

(If you are installing a 40' or 50' span, see appendix page "X-3" on end center bars before tensioning the gabled end.) For 30' and 60' spans, proceed as follows:

1. Tension the gabled end using standard ratchet hooked into baseplate adapter bar at each side of the structure. Tension each side evenly, so as not to draw the gabled end panel off center (See peak of beam). Tension until the kidder bottoms out against the baseplate. Otherwise, the wing wall will not fit properly.
2. To each end upright, attach a 1" web & winch strap (packed with the gabled end panel) by hooking top of strap into metal ring of the catenary fabric arch and the bottom into the hole provided on outside facing of each aluminum upright. Ratchet the winch handle until catenary arch is drawn tight.

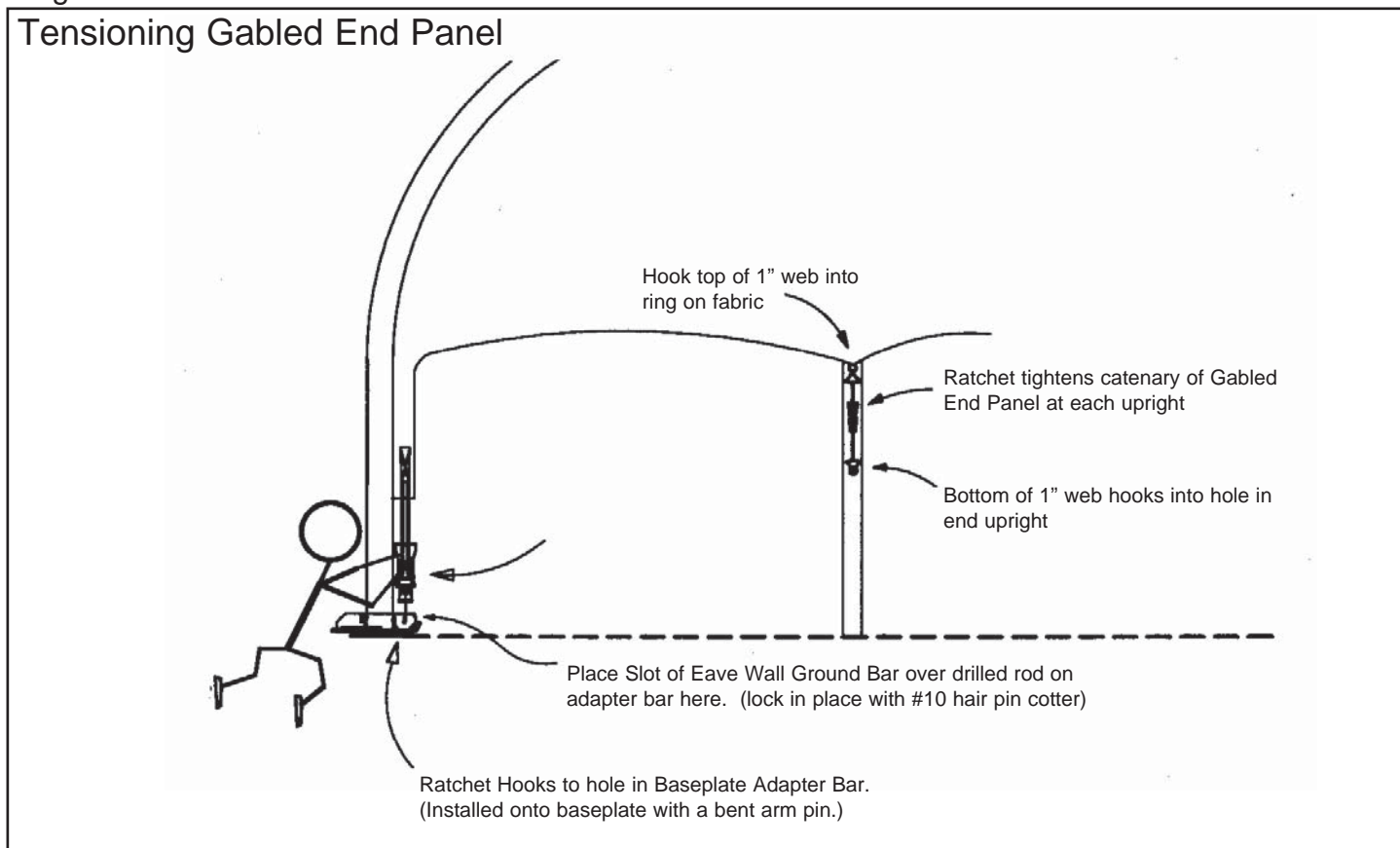

## Customizing the Gabled End Panel as an Internal Partition.

Note: The Gabled End feeds into the Liner or Inner beam channel. It is designed with a grommet line on the inside surface of its kidder tails. The wing eave walls lace to this grommet line (see page 21). If the Gabled End is installed onto the second beam of the structure to form a recessed end (portico), or if it is installed on a middle beam as an internal partition, it must be customized with special grommet lines to accommodate the lacing of adjacent middle walls, which would otherwise also use the liner channel. It is intended that the portico area of the recessed end will be cross-cabled and have no middle walls.

# ANCHORSPAN™ WALL SYSTEMS (with Loop & Grommet Lacing)

Top loop passes up and over the mid eave bar connector.  
2nd loop passes through 1st grommet, then interweaves with top loop. continue with loop and grommet lacing.

STANDARD TENT LACE  
(Each loop passes through grommet & preceding loop)

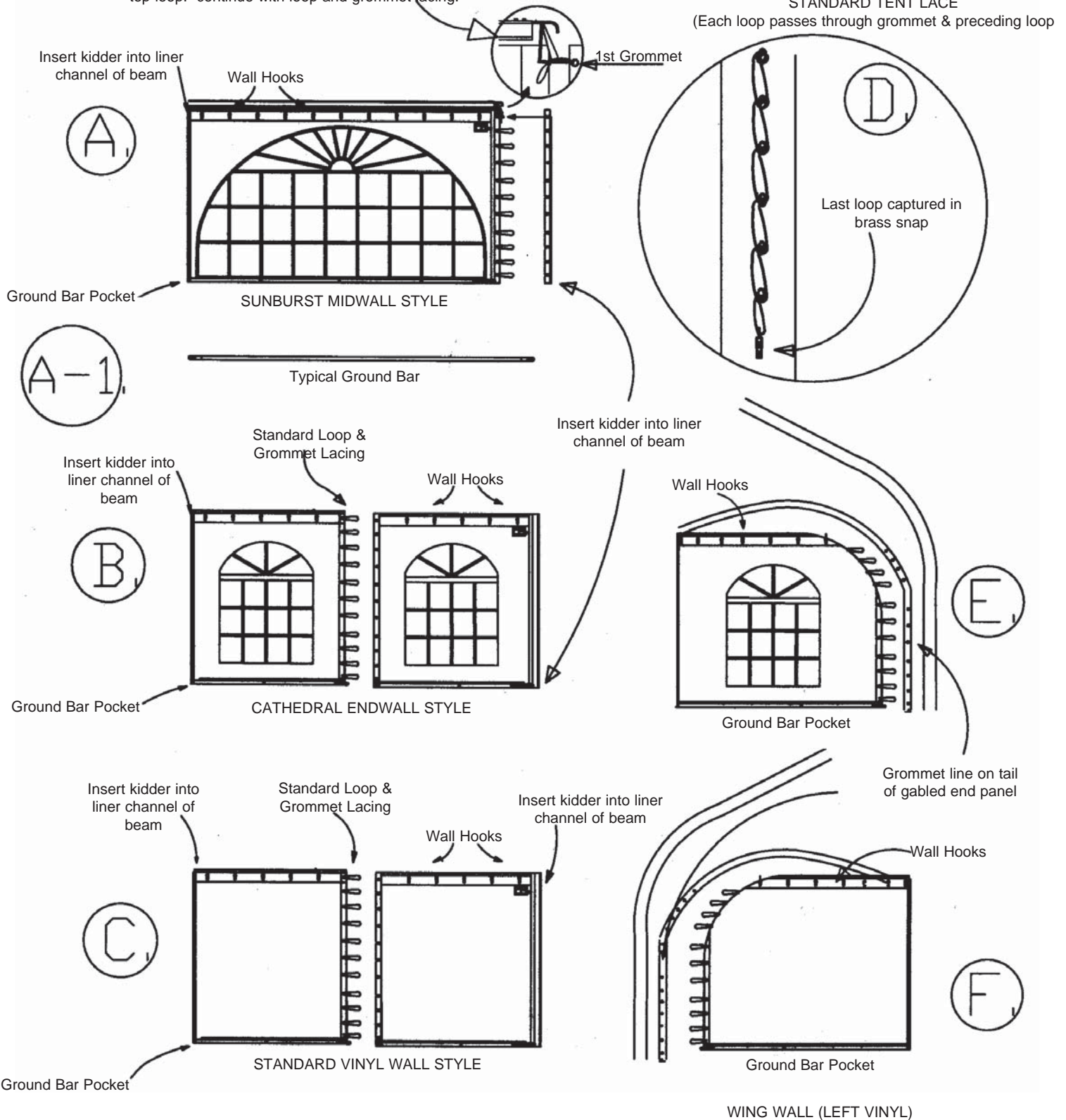

## Middle Wall Installation ( See “A” and “B” on preceding page.)

Standard vinyl middle walls are 2-piece with loop and grommet lacing down the center line of the wall. Sunburst window walls are also 2-piece but the lace line is along the beam, not down the center line. Midwalls are interchangeable on all AA AnchorSpans™ with 15’ beam spacing.

1. Face labels toward the interior and insert kidders of each mid wall section (bottom first) into the flare of the inside (liner) beam channel located just below the eave bar (see step #2 “alternate”).
2. Slide hooks at the top of the wall into the channel centered on the bottom of the eave bar. Or, as an alternate, slide 3 or 4 hooks into channel before inserting kidder (Step #1) to support the weight of the wall.
3. Pull the two sections of the wall together and lace, using the interweaving loop and grommet method. The top loop is a double loop. Pass the upper one up over the mid eave bar end connector (to the outside). The lower one passes through the first grommet, then interweaves through the upper loop. Continue, using the interweaving method shown. The last loop fastens to brass snap at bottom of lace line.
4. Insert mid wall ground bar into pocket at bottom of wall and connect to the baseplate, by trapping between hairpin cotters on bent arm pin.

## Wing Wall Installation:

The 1-piece wing wall is installed (labels to the inside) by first sliding the kidder edge down into the flare of the outside channel of the end upright column nearest the beam. Next, insert hooks at top of wall into the channel center in the bottom of the wing eave bar and slide the wall toward the beam. Lace the remaining edge (near the beam) onto the tail of the gabled end fabric, using intertwining loop and grommet lacing provided. The wing wall ground bar connects to the bent arm pin at the bottom of the end upright and to the drilled rod on the baseplate adapter bar (at the beam baseplate). Use #10 hairpin cotters as retainers for the ground bar.

## End Wall Installation:

End walls are similar to the 2-pc. vinyl mid walls, but their 20 ft. standard width makes them interchangeable on all AA AnchorSpan™ end wall locations. Install them in the same manner, using the outer channels of the end uprights to hold the kidder and sliding the wall hooks into the bottom (centered) channel of the end eave bars. Slide the two wall pieces together and lace with intertwining loop and grommet lace. Ground bars are inserted into pockets at bottom of wall and captured between hairpin cotters on the bent arm pin.

**Note:** Unlike the middle walls, end walls and wing walls use the smaller pattern cathedral window design familiar to users of Anchor pole tents and frame tents. This allows the end wall to lace down the centerline without disturbing the cathedral window pattern.

# ANCHORSPAN™ ASSEMBLY INSTRUCTIONS

## Appendix

- X-1 Appendix Index
  - X-2 Installation of Adapter Walls for connecting to other tents
  - X-3 40' and 50' Gabled Ends with End Center Bars -- also unique Lacing for Gabled Ends
  - X-4 Installation Time Chart -- an estimate of assembly time for various spans & lengths
  - X-5 Guidelines for Disassembly
  - X-6 Weights, Measures and suggestions for packing and storage
  - X-7 Template Drawings for the baseplates and the anchor plates for end uprights
  - X-8 Baseloads for Temporary Structures -- the wind reaction force on each anchor plate
  - X-9 Rafter Chart for Interchangeability beam components.
  - X-10 Assembly Sequence at a Glance.
  - X-11 Notes.....
  - X-12 AnchorSpan™ Limited Warranty & Maintenance Tips
- Back Cover -- Limits of Liability

## ADAPTER WALLS (to Fiesta® and Century® Frame Tents)

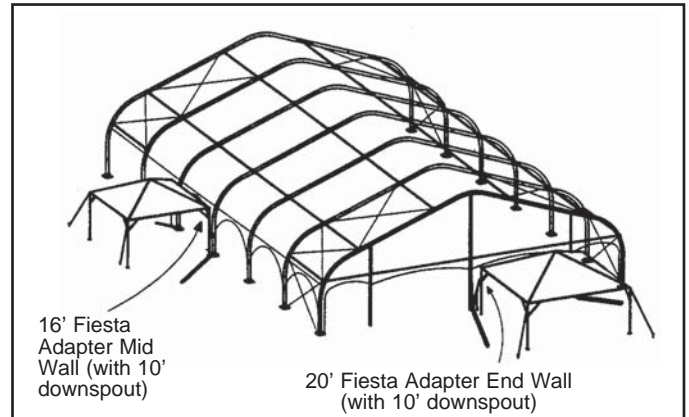
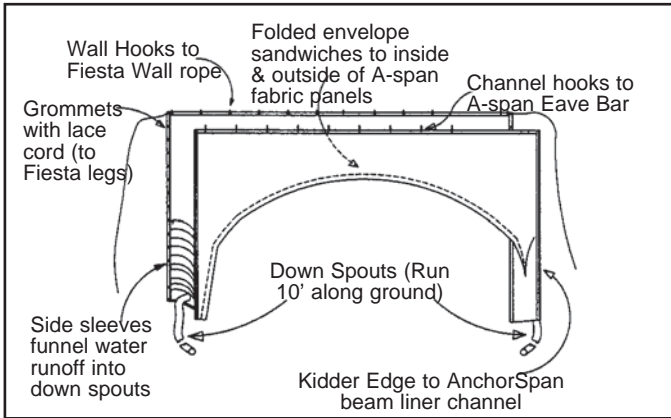

### For Transition to Fiesta® Frame Tents:

1. Feed 2 or 3 channel hooks at the top of the adapter (AnchorSpan side) into the bottom channel of the Eave Bar to support the weight of the adapter wall, then feed the kidder edges (at sides of adapter) down into flare of Liner Channel walls) or into the outer channels of the Gabled End Uprights (for end wall adapters).
2. Feed remaining Channel Hooks at top of adapter into the middle bottom channel of AnchorSpan™ Eave Bar.
3. Feed remaining half (Fiesta side) of adapter wall under the AnchorSpan™ tension arch toward the Fiesta Tent.
4. Attach wall hooks of adapter wall to the wall rope along the eave bar of the Fiesta Tent.
5. Using lace cord and grommets at side of adapter, lace the adapter wall to the legs of the Fiesta Tent.

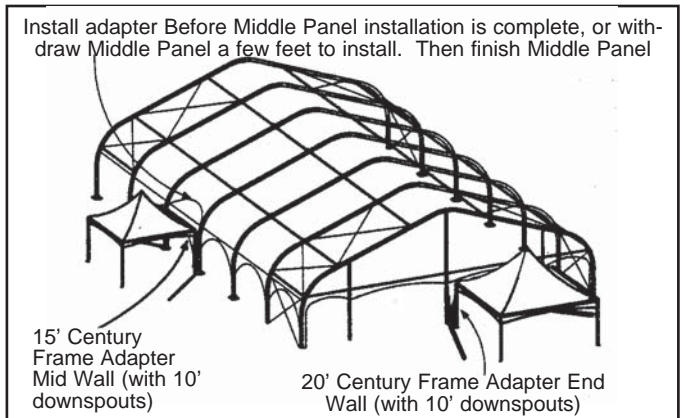
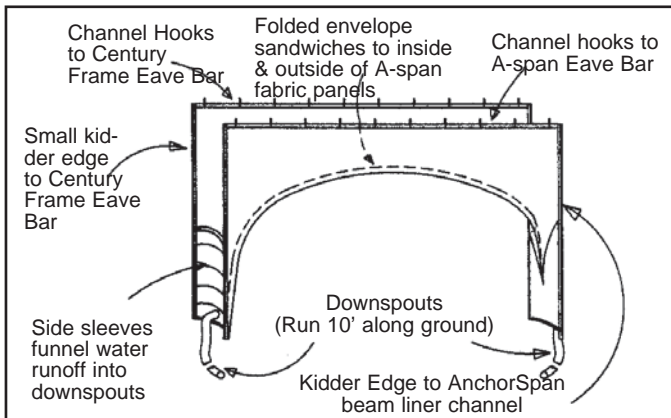

Note: AnchorSpan™ side has the larger kidder.

### For Transition to Century® Frame Tents:

1. Release tension on AnchorSpan™ panel. If mid wall location, withdraw mid panel by 3 to 4 ft up the channel.
2. Release tension on Century Frame Tent top.
3. Feed wall channel hooks into the bottom channel of the AnchorSpan™ eave bar. (Notch is near end of bar).
4. Feed wall channel hooks into Century Frame eave bar. (Notch is at the center of the eave bar, so the wall must be repositioned first toward one end of the eave bar and then the other to avoid drop out.
5. On each side of the adapter wall, feed the (2) kidder edges simultaneously downward into the AnchorSpan™ beam channel for midwalls (or end upright channels for end walls) and the outer channel of the Century Frame upright leg. Coordinate insertion of the two kidders carefully to avoid binding.
6. Fully install the middle panel (or re-tension the Gabled End Panel) and re-tension the Century Frame Top.

## End Framing with End Center Bars

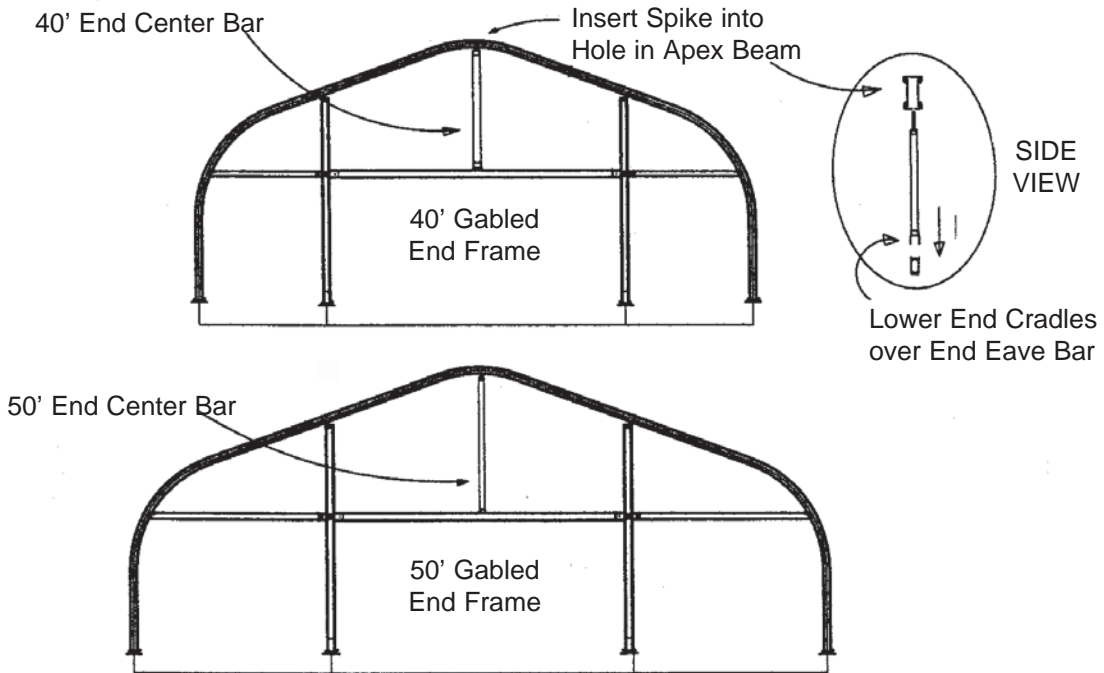

### 40' and 50' End Frames with the End Center Bar

Unlike the 30' and 60' Gabled Ends, the 40' and 50' End Frames do not have a center upright. To stiffen the end eave bar so that it does not deform under the tension of the Gabled End at the Lace Line, an end center bar is added to the 40' and 50' end frames only. The unique lace pattern for Gabled ends is detailed below:

1. Lace standard tent lace down from beam to the 4th loop up from the bottom of the lace line.
2. Loop the 2nd loop through the 1st, then back up to the 3rd grommet.
3. Feed the larger 3rd loop through the 3rd grommet and through the 2nd and 4th loops, then attach it to the stationary clip at bottom of the panel.
4. Clip the hook that rides on the web tail into the bottom channel of the end eave bar, then feed the tail into the web buckle on the clip and cinch it down tight.

### Unique Lacing Pattern for Gabled Ends

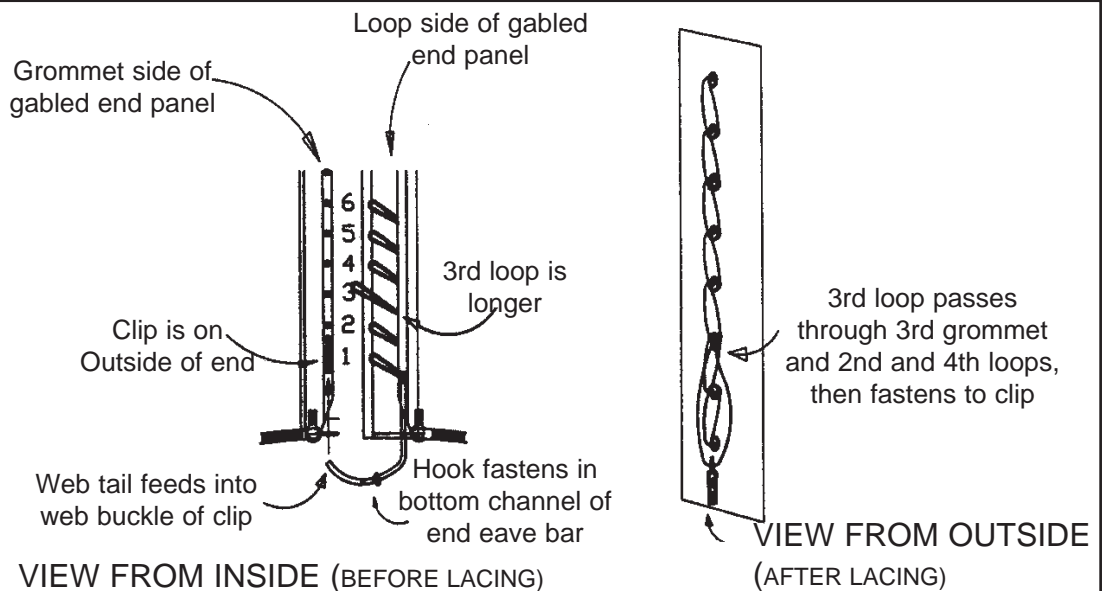

# AA ANCHORSPAN™ INSTALLATION TIME ESTIMATES

# of Beams	Length of Unit (15' beam spacing)	30'Span	40'Span	50'Span	60'Span
	In Feet	(Times include installation of 2 gabled ends)			
		Man Hrs. (Hours)	Man Hrs. (Hours)	Man Hrs. (Hours)	Man Hrs. (Hours)
3	30	12 -- (2)	13.2 --(2.2)	15 -- (2.5)	16.2 -- (2.7)
4	45	14.4 -- (2.4)	16.2 -- (2.7)	18.6 -- (3.1)	20.4 -- (3.4)
5	60	16.8 -- (2.8)	19.2 -- (3.2)	22.2 -- (3.7)	24.6 -- (4.1)
6	75	19.2 -- (3.2)	22.2 -- (3.7)	25.8 -- (4.3)	28.8 -- (4.8)
7	90	21.6 -- (3.6)	25.2 -- (4.2)	29.4 -- (4.9)	33 -- (5.5)
8	105	24 -- (4)	28.2 -- (4.7)	33 -- (5.5)	37.2 -- (6.2)
9	120	26.4 -- (4.4)	31.2 -- (5.2)	36.6 -- (6.1)	41.1 -- (6.96)
10	135	28.8 -- (4.8)	34.2 -- (5.7)	40.2 -- (6.7)	45.6 -- (7.6)
11	150	31.2 -- (5.2)	37.2 -- (6.2)	43.8 -- (7.3)	49.8 -- (8.3)
12	165	33.6 -- (5.6)	38.2 -- (6.4)	47.4 -- (7.9)	54 -- (9)
13	180	36 -- (6)	41.2 -- (6.9)	51 -- (8.5)	58.2 -- (9.7)
14	195	38.4 -- (6.4)	44.2 -- (7.4)	54.6 -- (9.1)	62.4 -- (10.4)
15	210	40.8 -- (6.8)	47.2 -- (7.9)	58.2 -- (9.7)	66.6 -- (11.1)
16	225	43.2 -- (7.2)	50.2 -- (8.4)	61.8 -- (10.3)	70.8 -- (11.8)
17	240	45.6 -- (7.6)	53.2 -- (8.9)	65.4 -- (10.9)	75 -- (12.5)
18	255	48 -- (8)	56.2 -- (9.4)	69 -- (11.5)	79.2 -- (13.2)
19	270	50.4 -- (8.4)	59.2 -- (9.9)	72.6 -- (12.1)	83.4 -- (13.9)
20	285	52.8 -- (8.8)	62.2 -- (10.4)	76.2 -- (12.7)	87.6 -- (14.6)
21	300	55.2 -- (9.2)	65.2 -- (10.9)	79.8 -- (13.3)	91.8 -- (15.3)
22	315	57.6 -- (9.6)	68.2 -- (11.4)	83.4 -- (13.9)	96 -- (16)
23	330	60 -- (10)	71.2 -- (11.9)	87 -- (14.5)	100.2 -- (16.7)
24	345	62.4 -- (10.4)	74.2 -- (12.4)	90.6 -- (15.1)	104.4 -- (17.4)
25	360	64.8 -- (10.8)	77.2 -- (12.9)	94.2 -- (15.7)	108.6 -- (18.1)

- Times** Numbers above indicate total man-hours . Figures in parenthesis are total elapsed hours using a crew of 6 workers.
- Technique** Above times are for manual installation using the Manual Installation Kit supplied by Anchor Industries
- Crew Size** Times assume a crew of 6 members with very little prior experience, with an experienced crew leader. Experienced crews may go faster. Also, we have not reduced the figures above to allow for the increase in speed that occurs on long structures, due to the speed gained from repetition.
- Site Conditions** Times may vary considerably due to site conditions and other uncontrollable factors.
- Sloped Ends** Above times include gabled end installation. For sloped ends only, reduce times by approximately 1 man-hour. To add sloped ends to a gabled end structure, add approximately 1 man-hour per end.
- Recessed Ends** Recessed ends would require the same installation time as the gabled ends shown above.

# GUIDELINES FOR DISASSEMBLY

## Fabric:

**Walls --** Remove Ground Bars; Unlace the 2-pc wall; slide hooks out of eave bar channel, and pull kiddie up and out of liner channels of beam and outer channels of end uprights.

**Gabled Ends --** Release tension by jamming ratchet handles to full vertical position and removing the web at end uprights and at beam baseplates. Release carabiners at top and bottom of lace line (use safety line if climbing on top of structure). Unlace the 2-pc end and pull each half downward and out through the channel flare in beam.

**Middle Panels --** Release tension by jamming ratchet handles to full vertical position and removing the web. Extract tails of tension arch up and through the flare in the outer beam channel. Grip kiddie tails to pull panel out of channel flares. Pull in same direction wind is blowing so that wind lifts panel.

## Frame:

**Remove End Framing --** Remove eave bars. Remove end upright stakes (or other anchoring devices). Rotate each end upright by 90 degrees so that it drops out of the slots in the bottom of beam. Lower carefully and remove.

**Remove Baseplate Hardware --** Before lowering beams, remove baseplate adapter bars, fabric tensioning winches, and all other baseplate hardware to avoid crushing them or damaging the beam as the beam is lowered to the ground.

**Lowering of Beams --** Remove middle eave bars; then follow instructions below: To release SpanLatch™ purlins, push pointed end of purlin hook into release hole (with orange trigger) in bottom of SpanLatch™ at an uphill angle until latch releases. Lift purlin off spacer. To avoid possible damage, keep purlin under control. Do not let it swing under its own momentum against the purlin stop. Use the gin pole (in same position as during assembly) to lower beams. Then, disassemble beam sections: (Leave bolts/hardware together as complete assemblies for storage).

Do Not Stand or Walk in the Falling Path of the Beam  
(Keep unlatched purlins under control. To avoid damage,  
Do not let them swing under their own momentum.)

### Step 1

#### HOLD ROPES

3 workers hold beam near vertical until joined by 3 additional workers to control beams descent

#### SAFETY ROPES

2 workers pull until last purlin is released and beam leans toward desired falling path, then join workers on hold ropes to control descent.

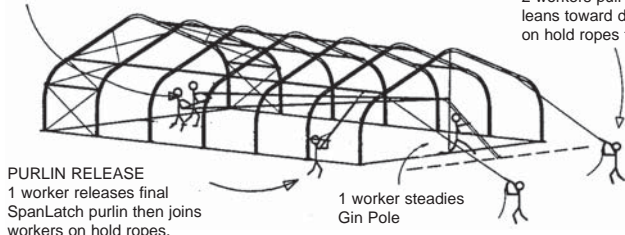

### Step 2

#### CONTROLLED DESCENT

4 or 5 workers control final descent of beam to ground

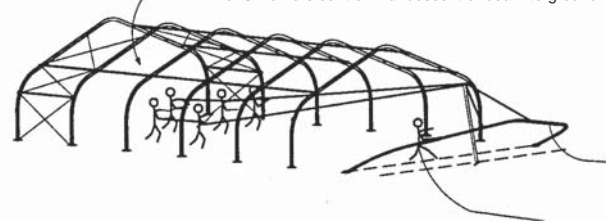

### Step 3

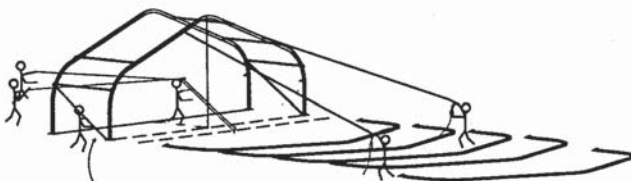

#### DIAGONAL BEAM BRACE

Before releasing the next to last beam, re-install diagonal beam braces. Do not remove braces until the last beam is controlled by the harness for descent to ground.

# AA ANCHORSPAN™ COMPONENT WEIGHTS & MEASURES

Part/Assembly Description	Weight Lbs. Ea.	Dimensions (Nominal)	Volume in cu. ft.	Packing Comments/Suggestions (Dimensions are to widest points)
Base Column Assembly	96	4"x4'8"x17'9"	[27.6]	4'8" is measured across the curve
Apex Assembly	89	4"x4'8"x14'7"	[13]	Stacks within the curve of base column
40' Rafter Assembly	33	4"x7"x6'4"	2.8	Includes splice in male end
50' Rafter Assembly	57	4"x7"x11'8"	2.3	Includes splice in male end
60' Rafter Assembly	90	4"x7"x17'	3.3	Includes splice in male end
Baseplate	31	16"x18"x6"	[1]	Sandwich 2 in space of approx. 1
Baseplate Adapter Bar	3.4	2"x2C"x15'	0.04	Pack in drum with other loose items
SpanLatch Purlin	26	3"x6C"x15'4"	2.1	Protect latching ends
Double SpanLatch Purlins	27	3"x6C"x15'4"	2.1	Protect latching ends
Purlin Bolt Assemblies	1.8	2"x2"x10"	0.02	Pack pre-assembled in drum
End Beam Bolt Assemblies	2.4	2C"x6"x10"	0.09	Pack pre-assembled in drum
Upright Bracket Bolt Assembly	2.7	3"x4"x10"	0.07	Pack pre-assembled in drum
Wing Eave Brackets	0.034	2"x2"x1C"	0.003	Store with end beam bolt assemblies
Mid Eave Bars 15'	29	2"x4"x14'11"	0.83	All eave bars stack well together
End Eave Bars 20'	40	2"x4"x19'11"	1.1	All eave bars stack well together
Wing Eave Bar 10' (Left)	18	2"x4"x8'10"	0.5	All eave bars stack well together
Wing Eave Bar 10' (Right)	18	2"x4"x8'10"	0.5	All eave bars stack well together
Wing Eave Bar 15' (Left)	29	2"x4"x13'9"	0.8	All eave bars stack well together
Wing Eave Bar 15' (Right)	29	2"x4"x13'9"	0.8	All eave bars stack well together
Midwall Ground Bar 15'	16	X"x1"x 15'3"	0.1	Easily strapped together in bundles
Endwall Ground Bar 20'	22	X"x1"x 20'3"	0.14	Easily strapped together in bundles
Wingwall Ground Bar 10'	10	X"x1"x 9'4"	0.06	Easily strapped together in bundles
Wingwall Ground Bar 15"	16	X"x1"x 14'4"	0.1	Easily strapped together in bundles
Adjustable End Upright	78	4"x7"x15'3"	3	(at shortest adj) Store fully assembled
End Upright for 60'	108	4"x7"x21'8"	4.2	Store fully assembled
Bent Arm Pin	0.64	C"x1C"x10"	0.004	Pack in drum with hair pin cotters
#10 Hair Pin Cotter	0.03	A"x1"x3"	0.0002	Pack installed on bent arm pins
Fabric Tensioning Winch	2.9	3"x4"x9C"	0.07	Pack in drum or similar
42" Shoulder Hd. Steel Stakes	12.8	2Z"x2Z"x43"	0.13	Pack in drum or similar
24"xD" Steel Stakes	2.1	1Z"x1Z"x25"	0.02	Pack in drum or similar
End Center Bar 40'	5.1	2"x3"x9'3"	0.4	Stack with eave bars and ground bars
End Center Bar 50'	6.2	2"x3"x10'10"	0.5	Stack with eave bars and ground bars
Cross-Cable/ Red-Green	4.2	1C"x2"x17'5"	0.4	Pack all together in drum or similar
Cross-Cable/ Red-Red	4.1	1C"x2"x17'	0.4	Pack all together in drum or similar
Cross-Cable/ Red-Blue	4.7	1C"x2"x21'5"	0.5	Pack all together in drum or similar
Cross-Cable/ Red-Yellow	4.3	1C"x2"x18'	0.4	Pack all together in drum or similar
Cross-Cable/ Red-Black	4	1C"x2"x15'6"	0.3	Pack all together in drum or similar
Stake Bar 2' (3-holed)	5.4	2"x2"x2'	0.06	Pack with loose hardware
Century Guy Winch	6.4	4"x4"x5"	0.05	Pack with loose hardware
AnchorSpan Installation Kit		15"x4"x20'	8.3	Kit below shipped in 1 container
Long Purlin Hook		1X"x11"x20'	incl.	Shipped included in installation kit above
Short Purlin Hook		1X"x11"x12'6"	incl.	Shipped included in installation kit above
Diagonal Beam Brace		2"x2C"x17'3"	incl.	Shipped included in installation kit above
Beam Hook & Harness			incl.	Shipped included in installation kit above
Fabric Hook & Harness			incl.	Shipped included in installation kit above
Eave Bar Cradle			incl.	Shipped included in installation kit above
Eye Fittings for Gin Pole			incl.	Shipped included in installation kit above

[ ] indicates items that stack easily within each other's shape

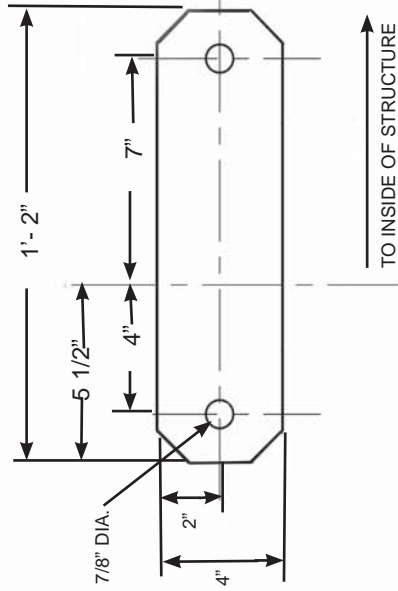
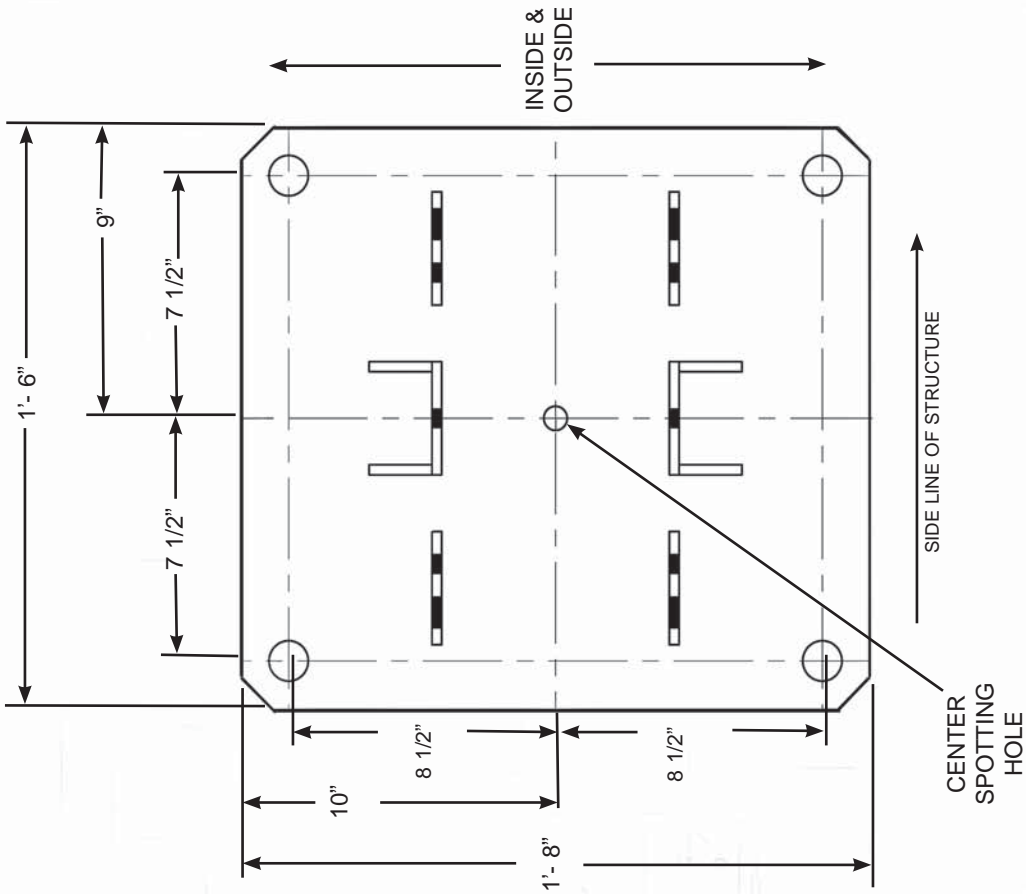

**END UPRIGHT BASE PLATE**

**SIDE BASE PLATE**

AnchorSpan "AA" TEMPLATE DRAWING  
FOR SIDE AND END UPRIGHT BASE PLATES

# AA ANCHORSPAN™

## BASE LOADS FOR TEMPORARY STRUCTURES

ASCE 7-93 Modified for Temporary Use Only  
(Revised 4-7-99)

Also see Introduction, Page 5 "For Permanent Installations".

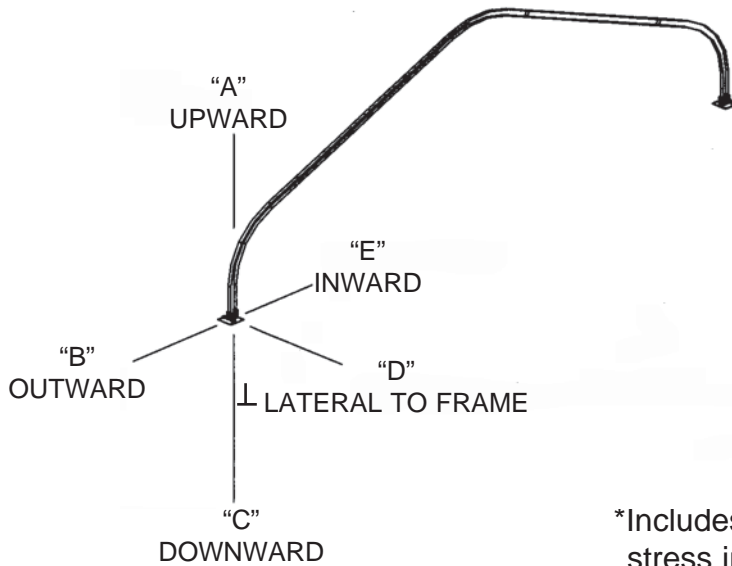

\*Includes wind loading -- appropriate stress increases may be used

NOTE: BASELOADS LISTED BELOW ARE IN POUNDS. APPROPRIATE SAFETY FACTORS MUST BE ADDED: VALUES SHOULD BE CONSIDERED NOMINAL ESTIMATES ONLY. ACTUAL VALUES WILL BE SUPPLIED ON FOOTPRINT DRAWING.

Span	Term of Use	Bay	Minimum # of x-cabled bays	A	B	C	D	E
30'AA	Temporary	15'	2	2400	330	980	1100	1700
40'AA	Temporary	15'	2	2900	560	1300	1000	2200
50'AA	Temporary	15'	2	3100	840	1600	1000	1800
60'AA	Temporary	15'	2	4100	1020	1700	1400	2100

In order for the AnchorSpan to meet the requirements of its engineering calculations and be certifiable for 70 mph winds under the ASCE Code modified for temporary use, it must be constructed properly with the specified minimum number of beams for the given span. It must be properly cross-cabled, and anchoring should be sufficient to withstand vertical and horizontal forces equal to, or greater than, those shown above on each baseplate plus an appropriate safety factor. When properly constructed, each beam can support 2 lbs per square foot (span times bay width) of additional dead weight.

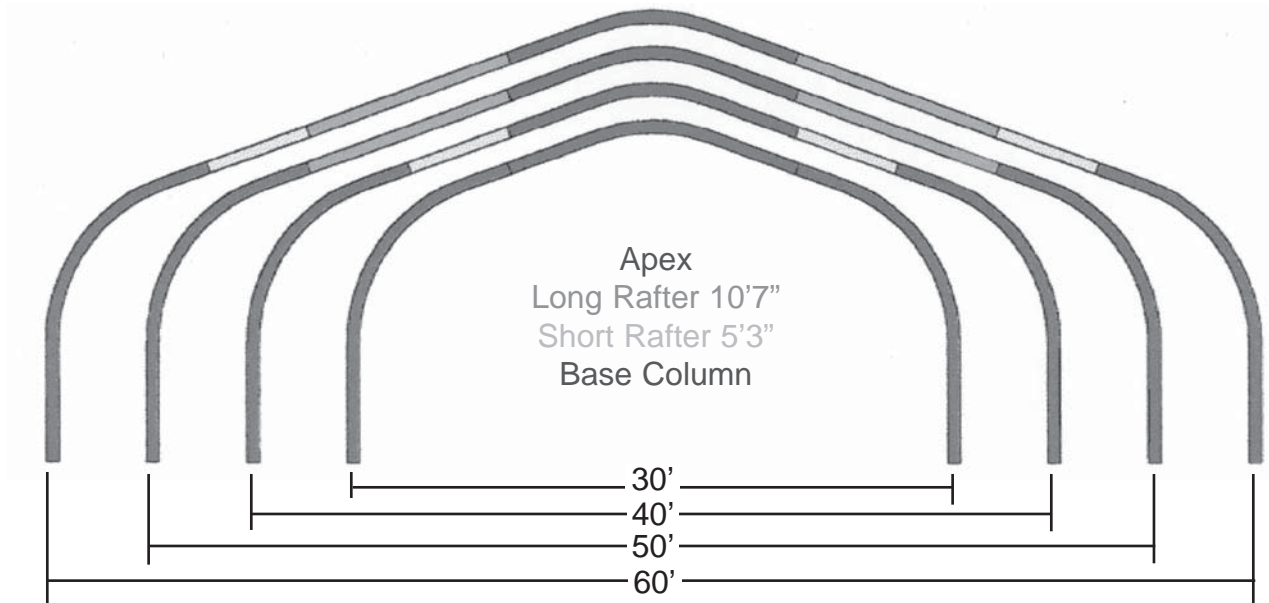

This color-coded diagram shows the common beam sections shared to allow the reconfiguration of the 60' wide unit into the 50', 40' and 30' wide units.

## Rafter Chart

- Consult the rafter chart above in selecting the components needed for the span you intend to install. Please note that:
- All spans use (2) base columns and (1) apex. The base column is a male piece at the upper end. The apex is female on both ends.
- The 30ft span uses no rafters.
- The 40ft span uses only a pair of short rafters to complete the beam arch.
- The 50ft span uses only a pair of long rafters to complete the beam arch.
- The 60ft span uses both a pair of short rafters and a pair of long rafters positioned as shown above.
- Male ends of the base column and **all** rafters point toward the apex in **all** spans. Male ends consist of pre-installed splices protruding from the end of beam section. We suggest leaving these splices installed during storage of beams.

Expertly manufactured in Evansville, IN, USA by:  
**ANCHOR INDUSTRIES INC.**

1-800-544-4445 • ph. 1-812-867-2421 • fax 1-812-867-0547 • www.anchorinc.com • e-mail: tents@anchorinc.com

# INSTALLATION SEQUENCE AT A GLANCE

1. **Unload basic tools**, tape measures, baseplates, stake drivers, and stakes. (**Note: If this is a certified installation, concrete footings & anchor bolts should be in place and cured prior to installation day.**)
2. **Layout footprint** pattern, and decide direction beams will be raised. Note that the first beam to be raised will receive the **end beam bolt assemblies** mentioned in the detailed instructions. Also, install wing eave brackets and end upright brackets on end beams, as necessary for your building configuration.
3. **Position baseplates and drive stakes**, first on one side of the structure, then on the other. While this is happening, unload eave bars, ground bars, installation kit and cross-cables along the outsides of the footprint area in their approximate assembly locations..
4. **Unload beam components**, pinning base columns to baseplates on the side where stakes are first being driven, then assembling beam parts, building toward the side where stakes are yet to be driven.
5. As stakes are driven in the far side baseplates, **complete each beam** by pinning it to the second baseplate, until all beams are installed flat on the ground.
6. Beginning with the 2nd beam to be raised, **install fixed ends of SpanLatch™ purlins** to all but the first beam to be raised. Do not install double latching eave purlins at this time.
7. On the 2nd beam and the last beam, **install quick-connect cross-cabing** according to their correct color-code pattern, letting turnbuckle ends trail to the ground in the direction of the first beam to be raised.
8. **Assemble the gin pole** with the cable hooks and harnesses and double eye fitting from the installation kit. Lay diagonal braces at sides of first bay and have Purlin Tools in a ready location. Position workers carefully on pull ropes and safety ropes according to detailed instructions given in this manual.
9. **Pivot first beam** to vertical and stabilize it quickly with the diagonal braces provided.
10. Reposition gin pole and **raise second beam**. Stabilize second beam by engaging SpanLatch™ purlins between first and second beams. When second beam is stable, divide crew so that half reposition the gin pole for the third beam and half **attach double latch eave purlins and cross-cabing in the first bay**. Connect all cross-cabing loose. Then tighten cross-cabing, starting at ground level and working upward to align beams vertically (or to right angles with the anchoring surface).
11. **Raise all beams**. Connect all purlins and attach and tighten cross-cabing in the last bay.
12. While some of crew **positions fabric bundles** between beams at the **downwind** side of the structure, others disassemble the gin pole and build it into the structure along with the other end uprights. Install end and wing eave bars at this time, but do not install mid eave bars until mid panels are installed, except in any bay where an adapter wall is to be used. Install eave bars so the fabric notch is to the inside of unit.
13. Using the Purlin Tool (pole), hang fabric hooks and harnesses to purlin holes on far side of the apex in first bay. **Pull first mid panel** to just beyond the apex, then drop fabric hooks back to ground level and finish installing the mid panel. Do not tension mid until eave bars **and** the adjacent mid panel have been installed.
14. **Install all mid panels** and tuck their tails. In each bay, install eave bars **before** mid panel is tensioned. Then attach ratchet and hook assemblies to baseplates and tension mid panels. **Note:** where adapter walls are to be used, **install the adapter wall before mid panel is fully installed or tensioned**.
15. Using Purlin Tools (poles), **install 2-pc gabled end panels** (half from one side, half from the other) and lace down the center and tension. For 40' or 50' spans, consult page X-3 appendix for end center bar installation.
16. **Install 2-pc mid walls, 2-pc end walls and 1-pc wing walls**. Note: it may be easier to install the wall ground bars in 2-pc walls before the wall has been completely laced down its center.

**Alternative** methods could be to install purlins as each beam joint is formed and to install mid panels as each bay of the beam system is completed. Each crew may have its own preferred variations on this sequence.

# NOTES



## AnchorSpan™ Limited Warranty

Anchor Industries warrants that the AnchorSpan™ prefabricated building will be free of defect on material and workmanship. We stand firm on our policy to correct any defect in the AnchorSpan™ or component thereof (including bearing the cost of freight in and out of Anchor Industries) during the first year of use on fabric and three years on frame components. Normal wear and tear or damage due to acts of God, exposure to chemicals, chemical agents or improper installation are not considered to be defects. All warranty repairs must be performed at Anchor Industries Inc., unless authorized by a company employee empowered to do so.

## Recommended Maintenance Tips

Fabric components should be cleaned as needed with mild laundry detergent and soft bristled brushes or mops and rinsed and dried thoroughly before being stored in the porous storage bags provided. Store on shelving in a cool, dry area to allow full air circulation. Bleaches, petroleum solvents and other caustic or harmful cleaning agents should not be used. Aluminum components such as beam sections and purlins are maintenance free except for periodic surface cleaning to remove grit that may have gathered in channels during assembly or disassembly. Steel components such as nuts, bolts, washers, baseplates and endplates for anchoring beams and fabric may require periodic maintenance in the form of sanding and repainting by the customer in order to prevent oxidation and realize their full potential life span.



**PHONE NUMBER**  
812- 867- 2421

**FAX NUMBER**  
812- 867- 0547

Anchor products are of superior design and operate best within the parameters of these instructions. It is imperative that the instructions be carefully read and **COMPLETELY FOLLOWED**. Please read installation instructions before the installation or removal of this product. Installation instructions are available online at [www.anchorinc.com](http://www.anchorinc.com) or by calling 1-800-544-4445.

### CAUTION:

1. For each installation, the installer is solely responsible for evaluating the site and the proper securing method determined. Some soils require different staking or securing than that provided with the tent. Due to this variety of soil conditions, these are the manufacturer's suggested sequence of installation procedures. Anchor's responsibility is limited to the manufacture of the tent parts and materials. We are not responsible for methods that installers may choose to erect and secure the tent to the ground.
2. The number of stakes suggested in the installation instructions does not necessarily meet all or any relevant codes on the site of the tent installation. The number of stakes suggested **will, in many cases, keep the tent erected**, however, due to various soil conditions; these stakes will be insufficient **to keep the tent secure in high winds**. It is the tent installer's responsibility, not the manufacturer, to determine the appropriate number of stakes to meet the necessary wind loads on the site. Regardless of the number of stakes we suggest, we make no representation or warranty as to whether this specific number of stakes will meet the local tent code. Anchor does not, nor can it make any suggestions, representation, or warranties about the adequate staking required at each specific installation site. Staking information provided in the installation instructions **is not a suggestion about what is necessary to meet a site-specific load**.

**For additional assistance, consult: "The IFAI Procedural Handbook For the Safe Installation and Maintenance of Tentage" and the IFAI Pocket Guide "Pullout Capacity of Tent Stakes", both available from the IFAI Tent Rental Division or on our website.**

3. Inasmuch as the weather is unpredictable, good judgment and common sense must be incorporated within installation guidelines. It is the responsibility of the tent installer/maintainer to determine the severity of the weather, proper time and method of installation and/or erection and disassembly. **Note: We recommend that snow and ice be removed from the tent surface as soon as possible because accumulation will damage the tent or fabric structure. Please consult with our Engineering Department about the maximum loads for each product.**

This product has been manufactured to meet code requirements. For the safety of all occupants, evacuation is recommended if threatening weather occurs, or if there is any doubt concerning the safe use of this product.

4. Proper safety equipment should be used at all times to insure a safe installation and take down. We suggest a careful evaluation be made to determine safety equipment needed, such as hard hats, steel-toe shoes, safety glasses and other as required. It is our desire that all installations are safe. Please be aware of hidden dangers both underground, i.e., gas lines, water lines, electrical lines, etc. and above the tent such as power lines and telephone lines.
5. Anchor stands behind its products in accordance with its standard Terms and Conditions of sale. A copy of our Terms and Conditions of Sale can be obtained by contacting Anchor at the telephone number and/or address on this document.